

OUTDOOR
FITNESS

CATALOG

element[®]
FITNESS

we bring the solution to your challenge

 TÜVRheinland[®]
LRTDEA

En1176 certified
En16630 certified



BENEFITS OF OUTDOOR TRAINING SOLUTIONS

Income opportunities. Equipped parks can also serve as a source of income for personal trainers. Self-employed trainers will be able to conduct outdoor fitness classes and provide clients with an alternative environment instead of the typical atmosphere at the gym.

The opportunity for specialized training. Obstacles created by Element Fitness can also serve as training places for representatives of such professions as firefighters, policemen, and paramedics brigades. All of them will be able to benefit from the “real world” environment and the ability to train even in adverse weather conditions.

Promotion of a healthy lifestyle. Open fitness parks contribute to the growth of a healthy community. These parks attract health-conscious people to parks and can often influence the behavior of people who do not do sports.

Available to all. Although there are many fitness center options, they can be expensive and inconvenient. Open fitness parks can eliminate these barriers, which is especially actual in regions where there are no fitness centers at all.

Benefit for health. Regular physical activity is necessary to maintain health and longevity. Many people tell us that they prefer to go in for sports outdoors. Exercises in the open air are also rated as more restorative in comparison with closed rooms, since they provide vital effects of sunlight, which increase the level of vitamin D.

Attracting people to new places. Outdoor fitness parks provide adults and children with opportunities for outdoor recreation and physical activity. People who may play sports regularly and want to change their surroundings can easily be attracted to new places in the fresh air.



En1176 certified
En16630 certified

OUTDOOR TRAINING STATIONS

COMPACT SOLUTIONS FOR RESIDENTIAL AND PUBLIC AREAS

Outdoor Functional Training Station is a reliable and effective tool for functional training. Combining various elements of equipment, you can create attractive smart training spaces, in municipality parks, schools, kindergartens, residential complexes, or hotels.

The outdoor training equipment collection has been designed together with its users. In its form language, it is open and airy and positively invites you to exercise. All Element Fitness products are available in predesigned setups to make your selection easier. You can also fully customize the product completely to your own liking, as Element Fitness offers an enormous amount of different attachments and colour options. This makes it easy to create sports grounds that are suitable for users of all fitness levels and ages.

One of our core ideas is to provide children and their parents with a chance to move and exercise together – therefore our compact solutions can take an honourable place in every public area and residential place.

SKU: 30-05878

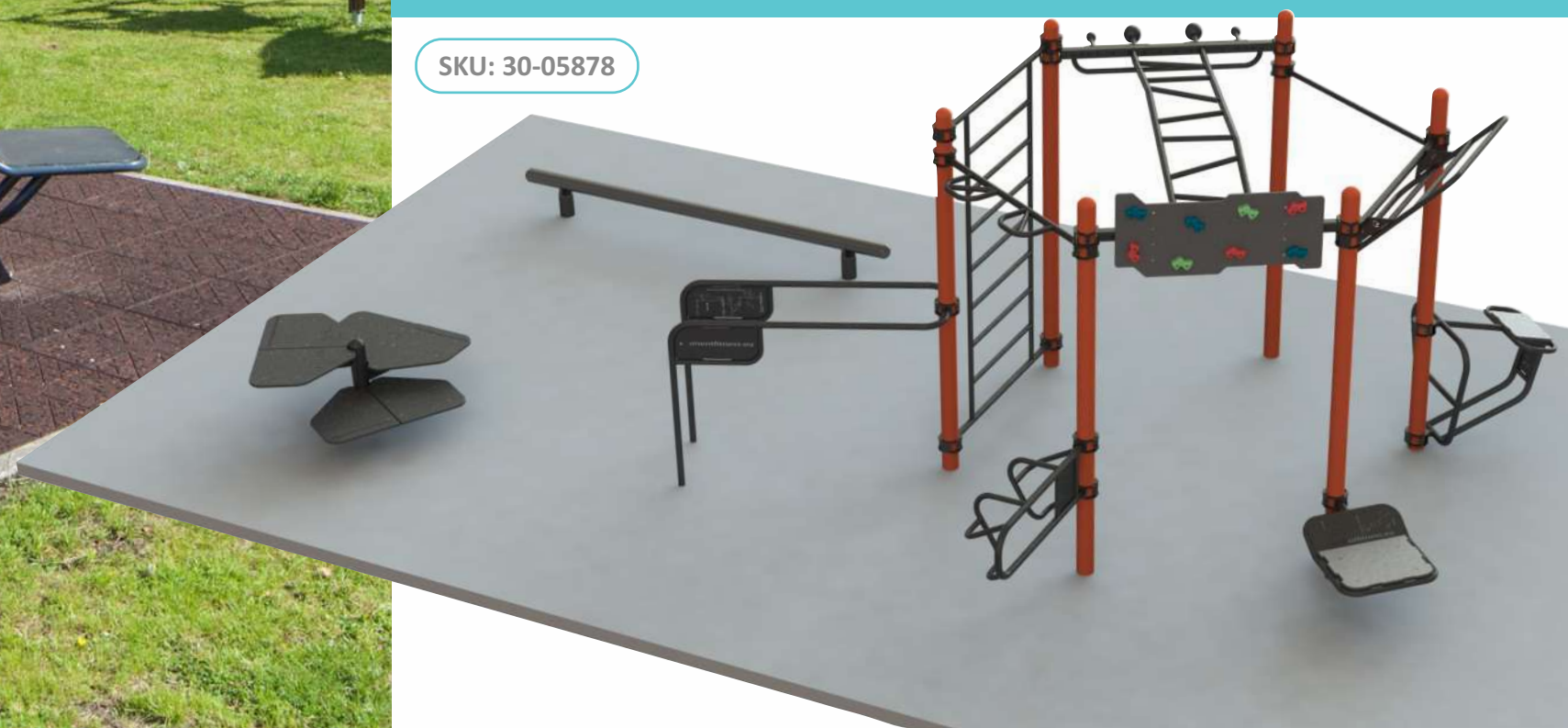

OSTFOLD CAMPUS NORWAY



Together with our partners, we wanted an outdoor gym to help boost the activity and wellbeing of the students in Ostfold Campus. We also wanted the activity to go much further - so we have splitted the area into 2 zones. The first one was devoted to classical functional fitness and basic movements, therefore the second was more oriented towards calisthenics, and we also incorporated several OCR elements, where the athletes could have a taste of obstacle running.

Our engineers and designers know that our clients and our partners will expect excellent opportunities for physical activity. Their equipment and features must also be different from everything else that's available and must bring additional value to the landscape. It's equally important to design for people's wellbeing - promoting fitness benefits with inspiring beginners and students to get active.

ARCO REAL ESTATE



For the new project in Tallinn, Kodulahe kvartal, the challenge was to design and install an outdoor training solution to complement a new premium estate building and surrounding area, creating a multi-use exercise zone with a modern look. The space had to be engaging to encourage regular and enthusiastic use by all residents. The final result was a complete transformation and is immediately popular with residents and children, who now have a high-quality activity area that can be used by everyone for years and years to come.



DAUGAVPILS CITY COUNCIL



Since our company comes from Latvia - it is not a surprise, that we actively participate in outdoor functional training gym tenders in our own town and actively promoting different sporting events. Every time we try to propose equipment with a fresh new design and layout.

One of the main features of these installations apart from outstanding quality was its very own embroidered laser-cut exercise hints, located on every piece of equipment. Thanks to them, even beginners can get advice, what exercises are available at any station.

COMPACT SOLUTIONS FOR RESIDENTIAL AND PUBLIC AREAS



SKU: 30-01076



SKU: 30-03820-A-0001

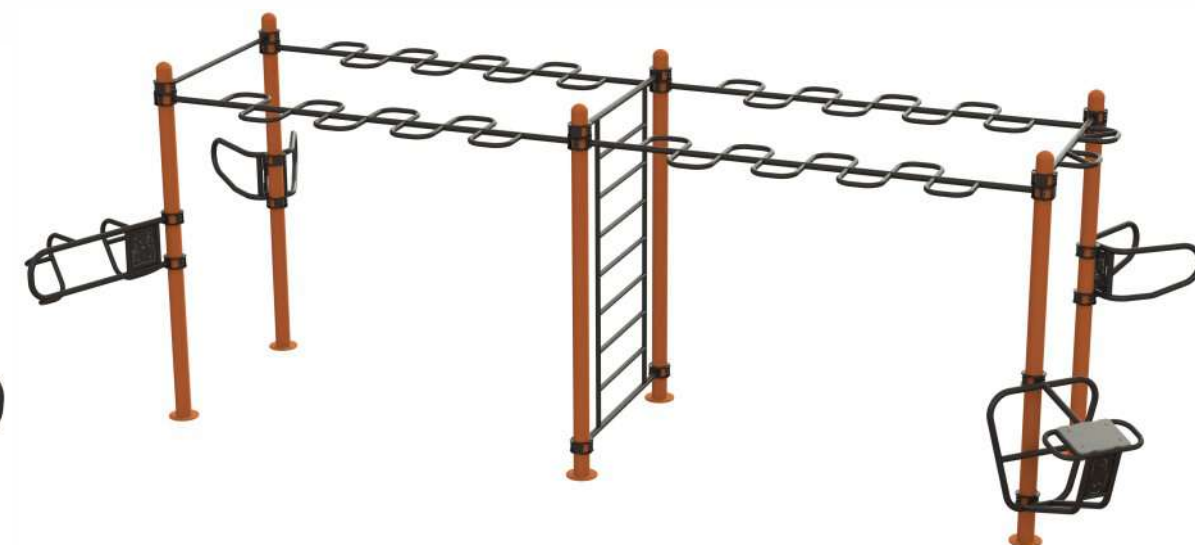

SKU: 30-03850-C-0003A01



SKU: 30-03870-D-0001



SKU: 30-03870-D-0004



SKU: 30-03840-B-0001



SKU: 30-03850-C-0002

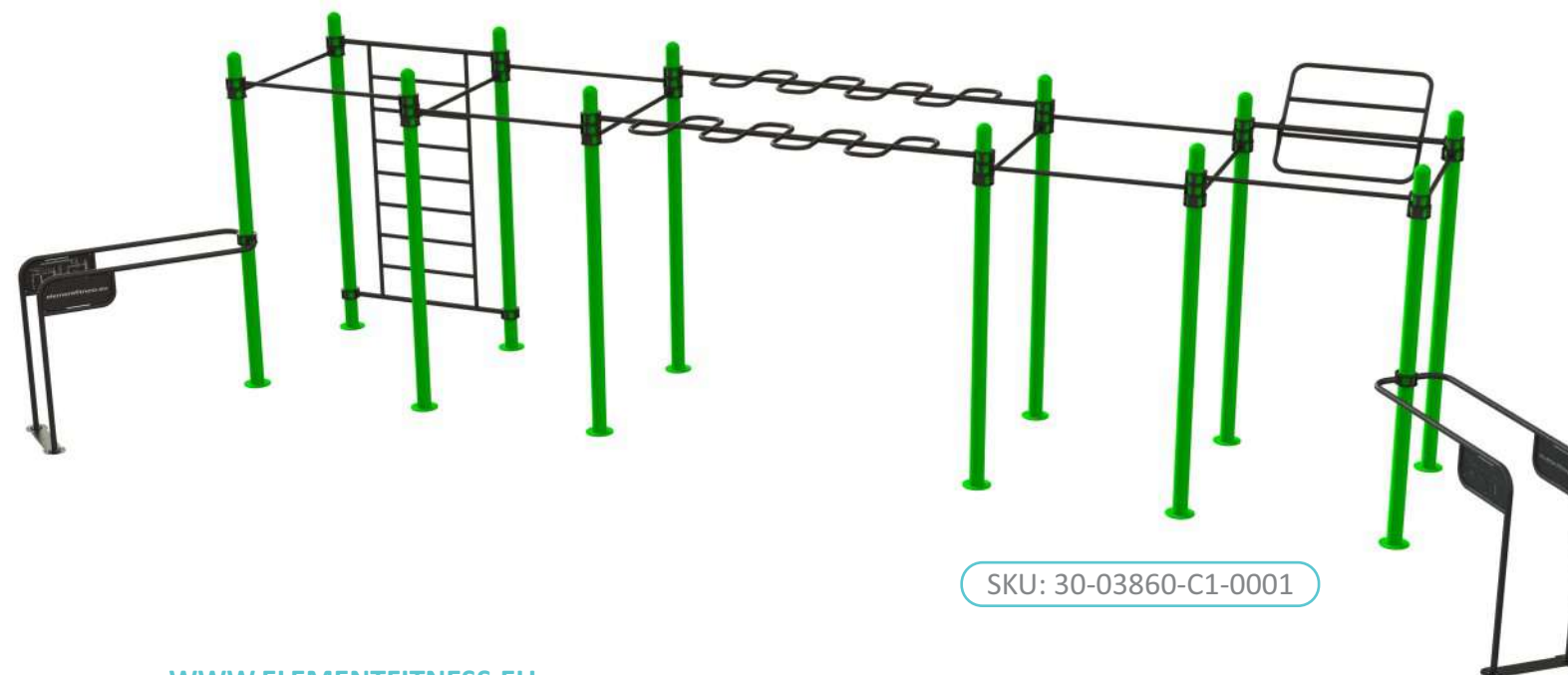

SKU: 30-03860-C1-0001

COMPACT SOLUTIONS FOR RESIDENTIAL AND PUBLIC AREAS



SKU: 30-03840-B-0002



SKU: 30-03850-C-0001



SKU: 30-03880-D1-0001

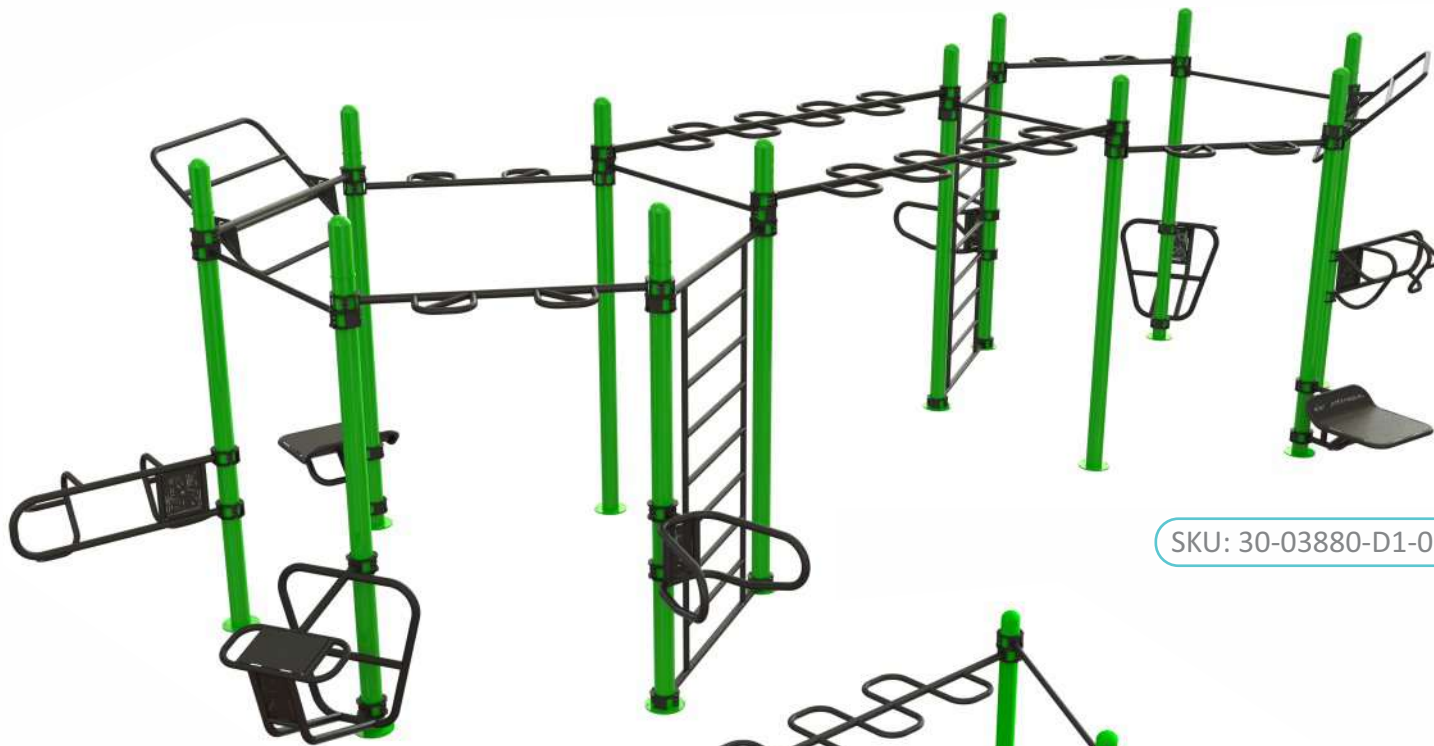

SKU: 30-03880-D1-0003



SKU: 30-03890-D2-0002



SKU: 30-03890-D2-0001



SKU: 30-03860-C1-0003



CUSTOM THE RIGHT SOLUTIONS FOR YOUR COMMUNITY

SKU: 20-00695
MULTI GRIP BAR



SKU: 20-00314
PULL-UP BAR



SKU: 20-05814
INCLINED CLIMBING BOARD LONG



SKU: 20-05813
INCLINED CLIMBING BOARD

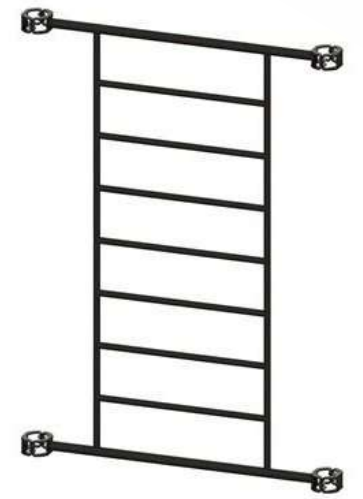

SKU: 20-00943
LADDER

SKU: 20-00355
MONKEY BAR

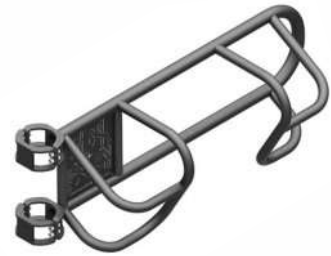
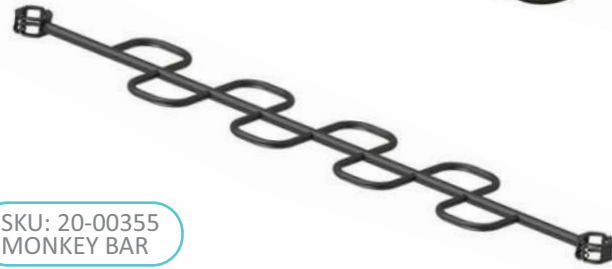

SKU: 20-01065
ROW PUSH UP DIP BAR ASSISTED SQUAT

SKU: 20-05881
CLIMBING BOARD



SKU: 20-00520
V-SHAPE DIP BARS



SKU: 20-01201
PLYO PLATFORM



SKU: 20-01268
FLYING PULL UP BAR



SKU: 20-06023
SHELF



SKU: 20-00525
SIT UP PUSH UP GHD

SKU: 20-02339
BOARD FOR STANDING PUSH UPS



SKU: 20-03206
LONG DIP BARS

STREET WORKOUT & CALISTHENICS RIGS



SKU: 30-03890-D2-0007



SKU: 30-03870-D-0008



SKU: 30-03830-A1-0003

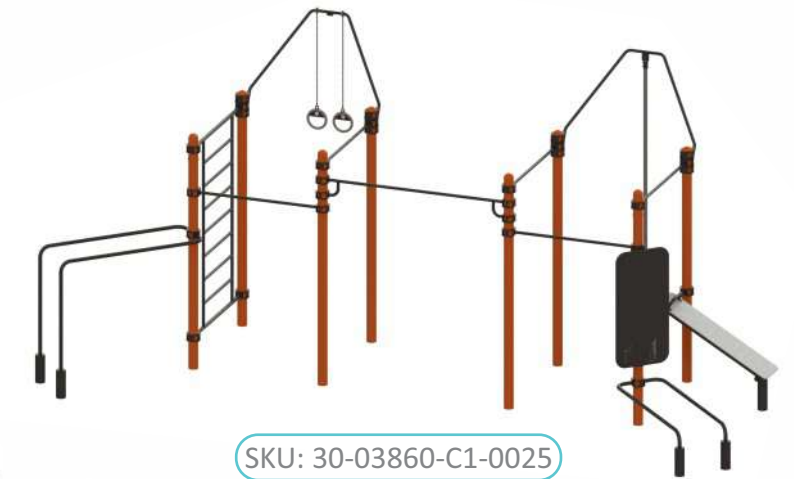

SKU: 30-03860-C1-0025



SKU: 30-03840-B-0011

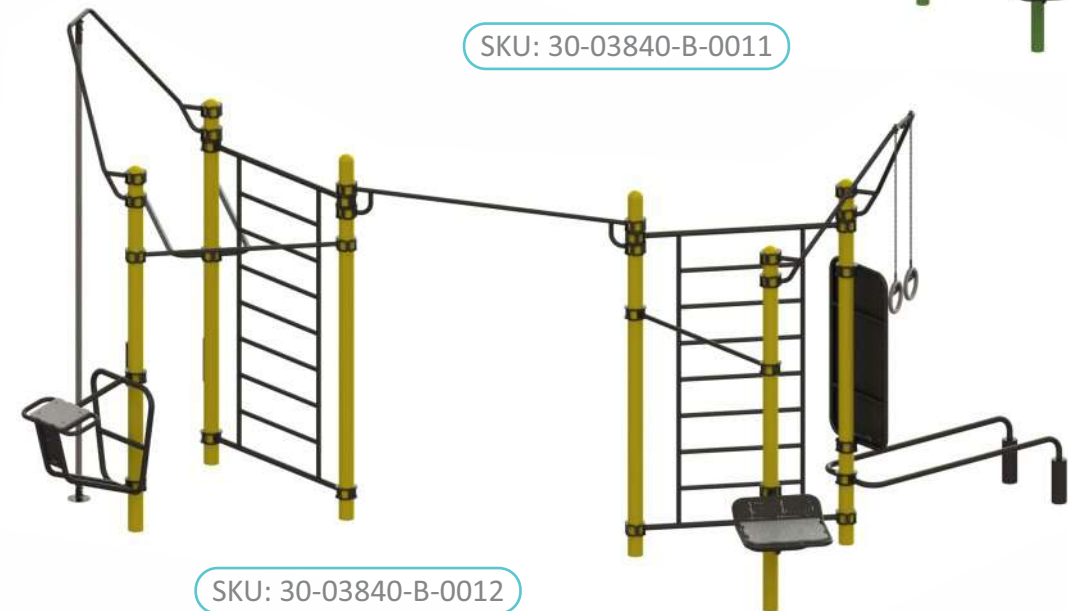

SKU: 30-03840-B-0012

We are proud to present a range of truly amazing designs that have been developed in collaboration with top competing athletes from the industry. Our calisthenics rigs are perfect for anyone looking to take their body weight training to the next level. Whether you're just starting out on your fitness journey or you're an experienced athlete looking to push your limits, we have a setup that will meet your needs. Our rigs are designed to be strong, durable, and versatile, with a range of attachments and accessories that allow you to customize your workouts to suit your goals. Whether you're looking to build muscle, increase strength, or improve your overall fitness, our rigs are the perfect addition to your home gym or municipality playground. So take a look at the designs on offer and get ready to take your calisthenics training to new heights in the new year!



SKU: 20-10165

SKU: 20-11128



SKU: 20-10166



SKU: 20-11136

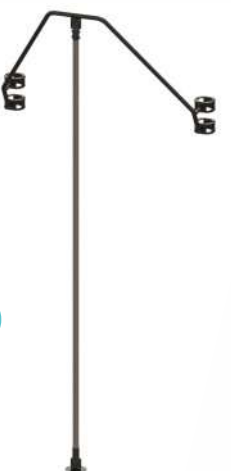

OBSTACLE COURSE RIGS



SIMPLE SOLUTIONS FOR COMPLEX NEEDS

SKU: 30-07580-E-0002

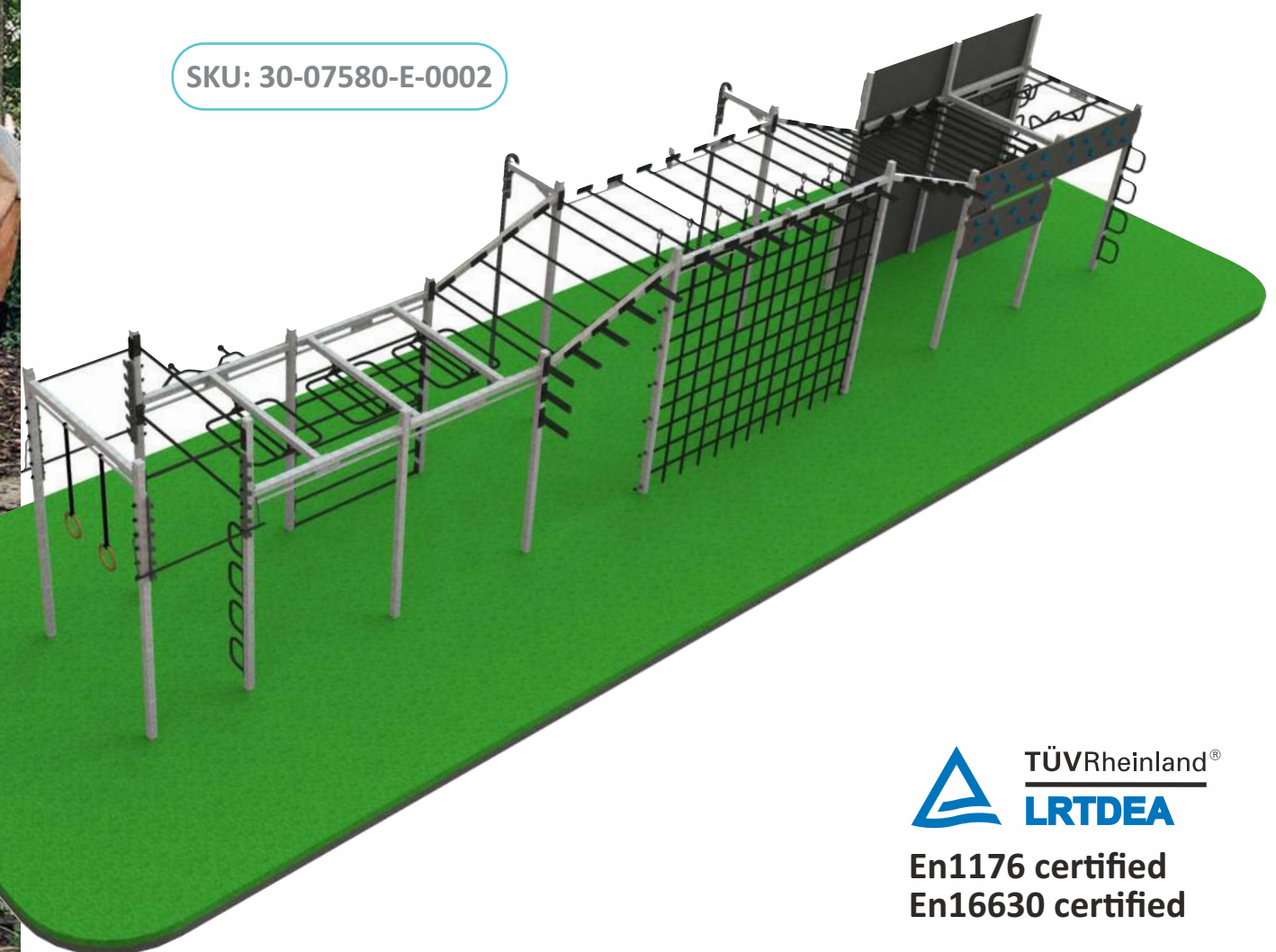

We used to run, walk, jump, and crawl as natural actions. Before it was the way how people completed most things, however, present-day life has changed a lot, but work in offices and schools has made people more static. Obstacle courses return us to our foundations with regular development for increased well-being and happiness.

Usually we come up with tailored rig designs, where we utilize plenty of core and grip training possibilities for the big groups of people. The constructions are spiced up with climbing cargo nets, salmon ladders, Swedish ladders for stretching, climbing ropes and large climbing walls with professional HRT and fiction climbing holds. Moreover, we bring fully EN16630-certified solutions, so all safety standards are kept.

TÜVRheinland®
LRTDEA

En1176 certified
En16630 certified

WWW.ELEMENTFITNESS.EU

STROPI PROMENADE



The movement of Obstacle Course Running is getting more popular with every year and this was one of the reasons, why we have started to develop this product line. For OCR athletes and climbers, grip, back and hand strength is crucially important, together with general fitness and stamina.

In order to achieve these goals, we put up lengthy training rigs equipped with a range of attachments and challenges, combining strength and obstacle training.

OBSTACLE TRAINING ELEMENTS

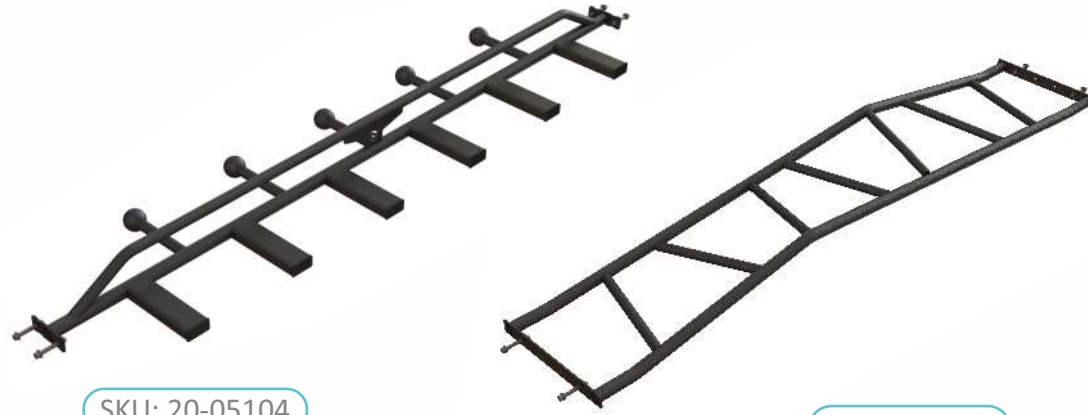

SKU: 20-05104

SKU: 20-05092



SKU: 20-05672

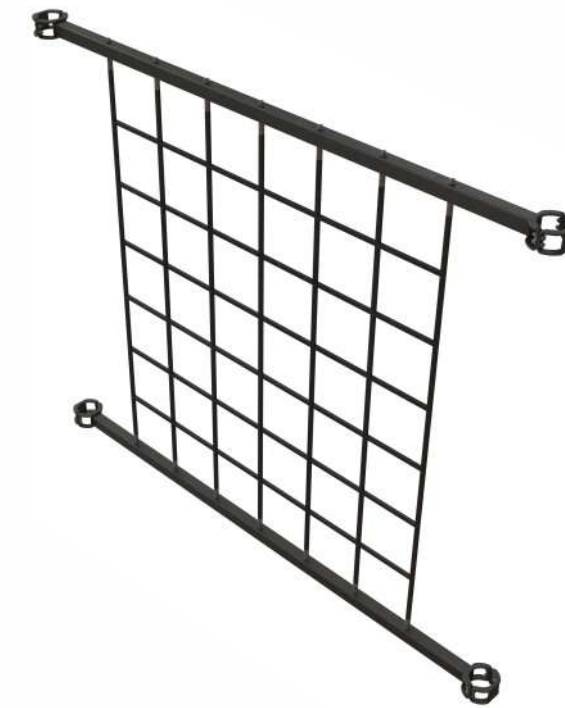

SKU: 20-06020



SKU: 20-05130

SKU: 20-05875



SKU: 20-06023



SKU: 20-05966



SKU: 20-05107

SKU: 20-06021



SKU: 20-05952

OBSTACLE PARKS FOR PUBLIC AREAS



SKU: 30-06313

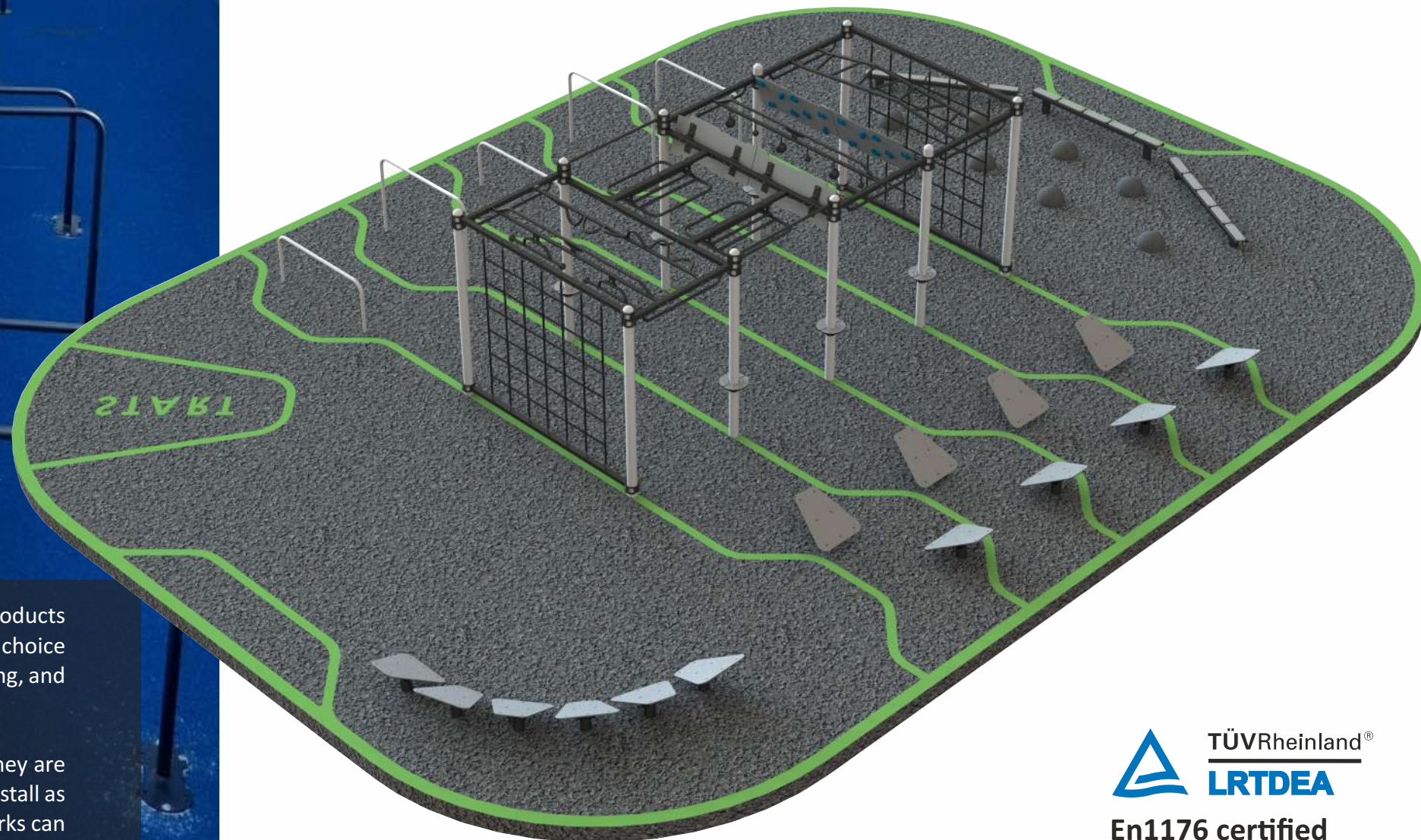

The obstacle park collection is durable, affordable, and almost maintenance-free. The obstacle products provide inspiration for running and functional training enthusiasts of all ages and are an excellent choice for an urban environment. Athletes can use their energy for climbing, hanging, balancing, swinging, and jumping.

The obstacle parks conform to the European Standard for Playground Equipment EN1176, so they are also suitable for schoolyards and free access playgrounds. All the obstacle parks are as easy-to-install as our standard equipment and will provide a glow of modern to any surrounding. The obstacle parks can be easily expanded and fully customized.



En1176 certified
En16630 certified

Idre Fjäll

When the resort of Idre Fjäll decided to add fitness, they knew that a multigenerational space was needed to help ensure that local families and tourists found the exercise options meaningful. They wanted to ensure that, while the fitness area would be designed for adults, there was a family-friendly area as well, so parents didn't have to worry about finding a caregiver to watch their children when they wanted to work out. They also wanted to be sure that the space made sense for athletes at all levels of fitness, from beginners to competitive levels.



Our team worked with our trusted partners TRESS Sport & Lek AB to fulfill their vision of a fitness and play area for people of all abilities. The resulting area is a model fitness environment, which includes a multi-arena, climbing wall, outdoor gym, playground, and OCR course designed and made by Element Fitness.

PARKS FOR PUBLIC AREAS

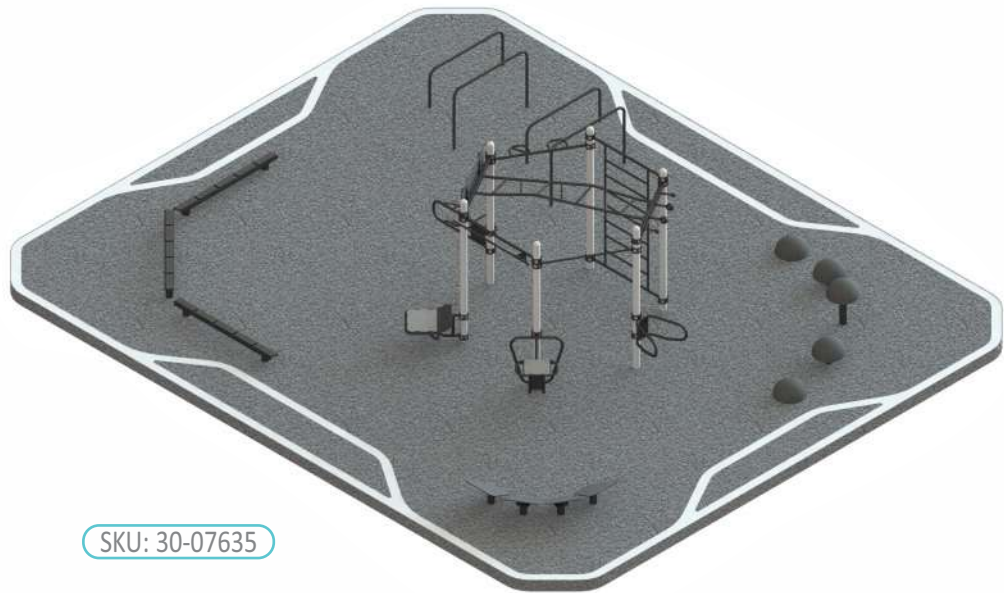
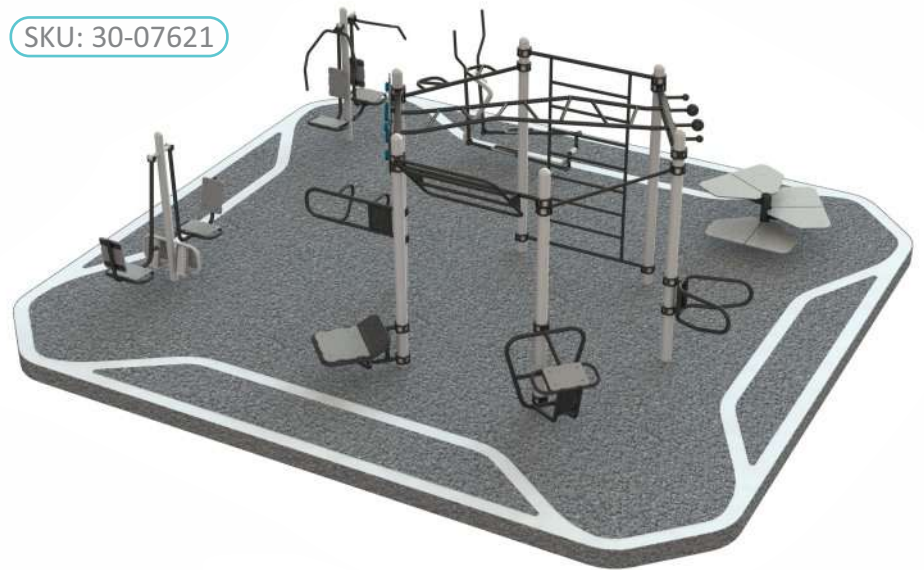
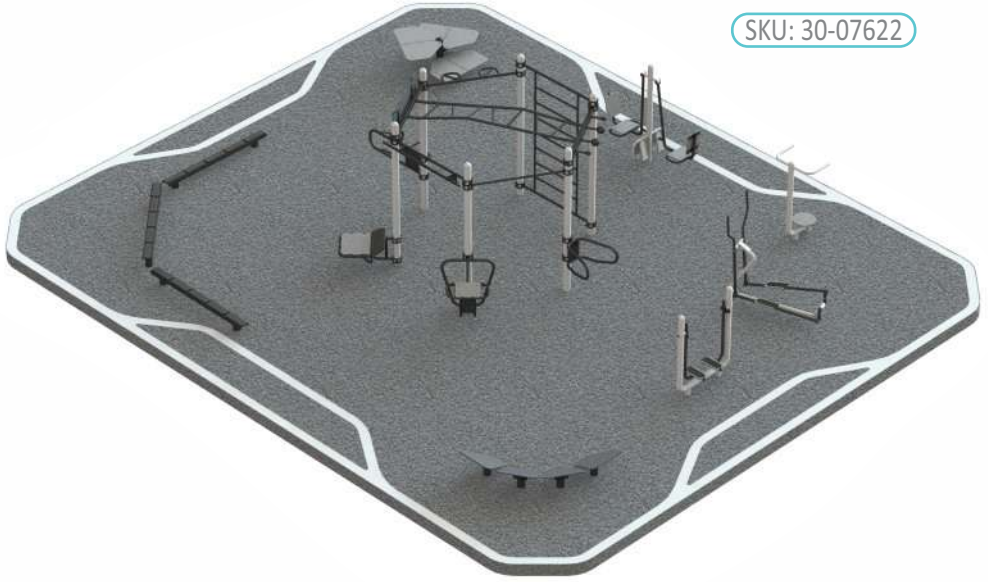
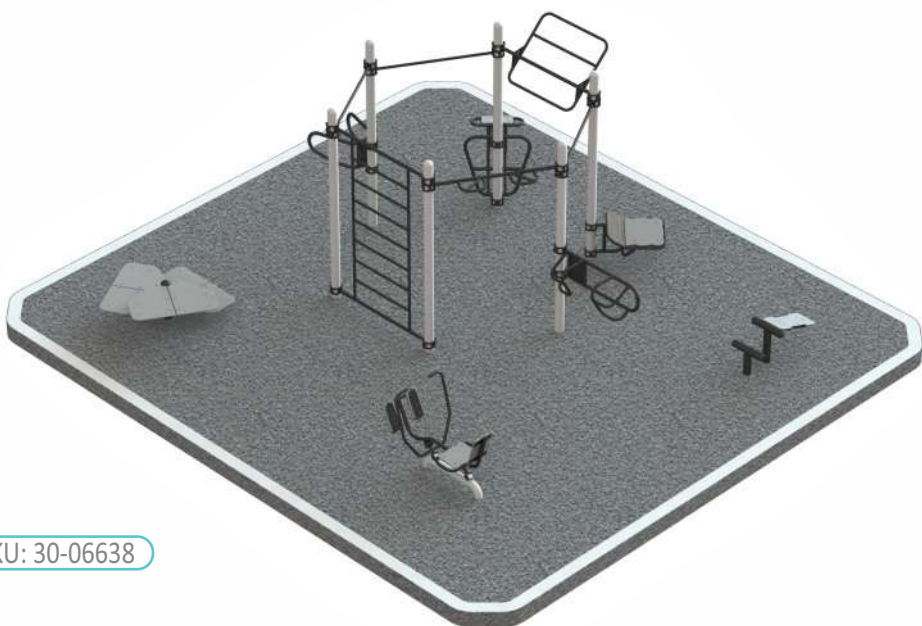

LARGE PARKS FOR PUBLIC AREAS

SKU: 30-07638



SKU: 30-07636



SKU: 30-07626



GROUND OBSTACLES



SKU: 20-07021
STEP AND CALF



SKU: 20-00446
PUSH-UP STATION



SKU: 20-10966
SIT-UP BENCH



SKU: 20-04256
FLAT BALANCE BEAM



SKU: 20-04533
UNSTABLE FLAT
BALANCE BEAM

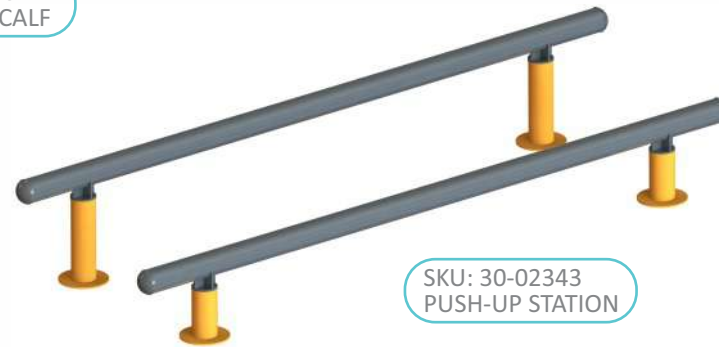

SKU: 30-02343
PUSH-UP STATION



SKU: 20-04256
BALANCE COURSE



SKU: 20-07024
CURVE BAR
FOR MOTOR SKILLS



SKU: 30-05122
UP AND DOWN



SKU: 30-06000A00
RUNNING CURVE

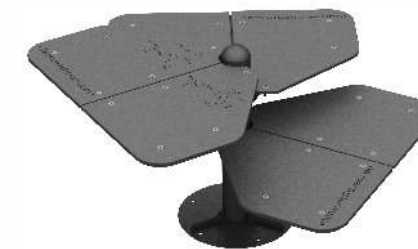

SKU: 20-00400B
MULTI-LEVEL PLYO
PLATFORM (40-50-60)



SKU: 20-03828
DIP BARS
1400/1500 (HALF)



SKU: 20-05475
NINJA SPHERES



SKU: 30-05202A00
NINJA STEPS

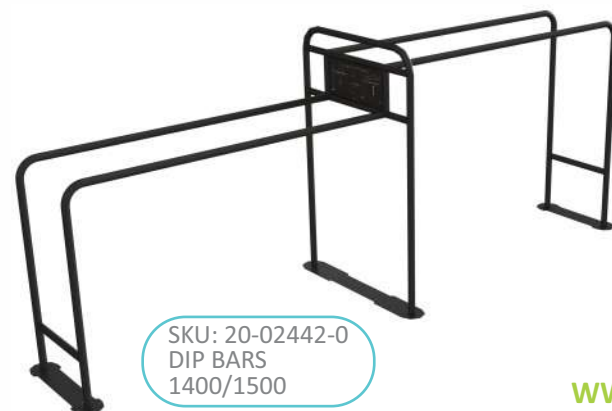

SKU: 20-02442-0
DIP BARS
1400/1500



SKU: 30-05476A00
LONG RUNNING CURVE

OBSTACLE AND FITNESS TRAILS FOR PARKS AND PUBLIC AREAS

Functional fitness trail in the heart of the city

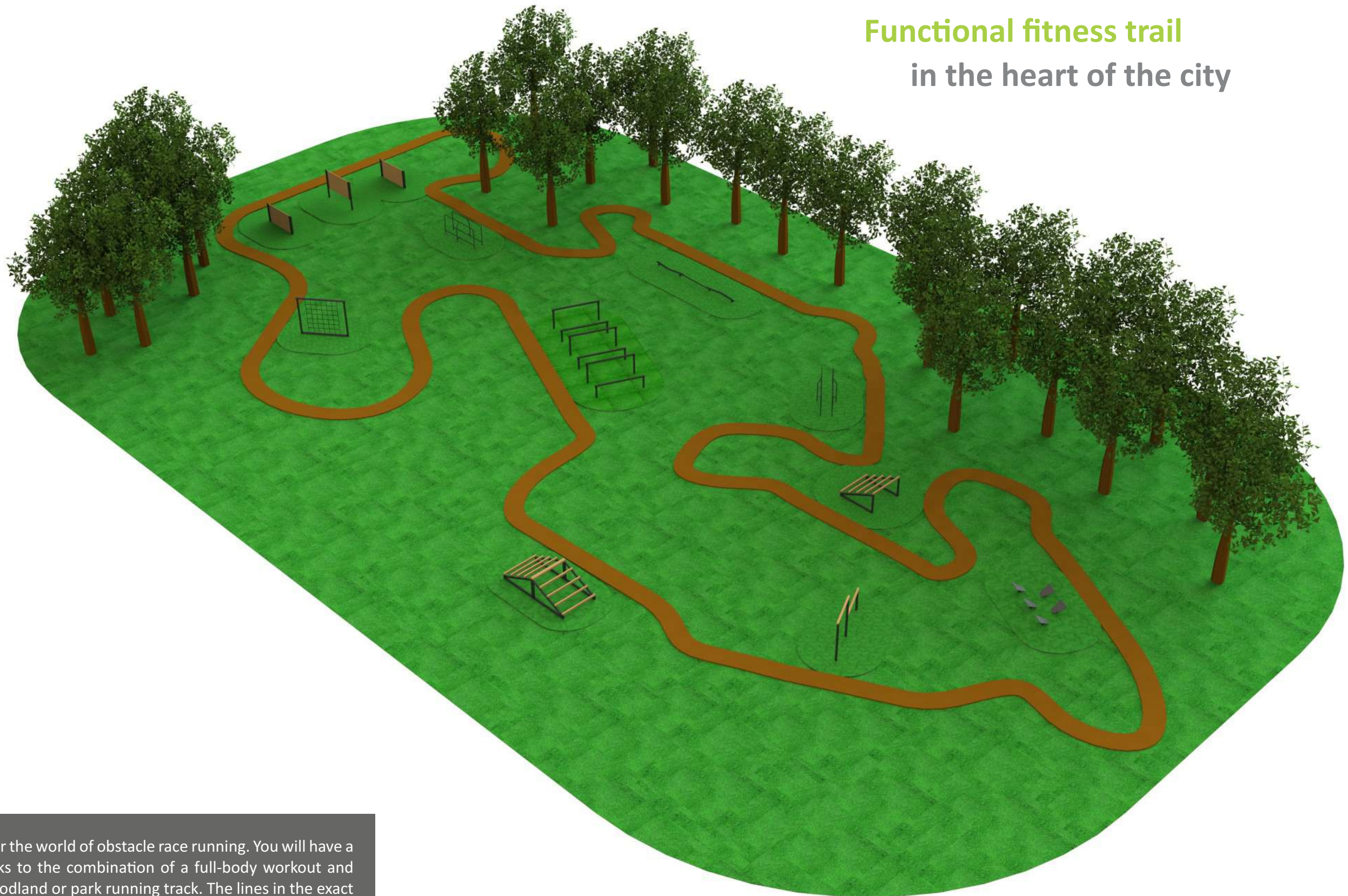

Without leaving your favorite running spot, enter the world of obstacle race running. You will have a beautiful experience overcoming hurdles thanks to the combination of a full-body workout and running, clashing with the surroundings of a woodland or park running track. The lines in the exact center of each station can be used to see the organic and straightforward forms of nature.

Municipalities have the choice to set up fun recreational areas next to the forests' or parks' wild running routes using trail equipment. The stations have been designed to be as simple to install and maintain as feasible. These solutions would be an eco-friendly option because we have reduced the use of plastic parts at the same time.



En1176 certified
En16630 certified

OBSTACLES FOR PARKS AND TRAILS



SKU: 20-06752
WEAVER

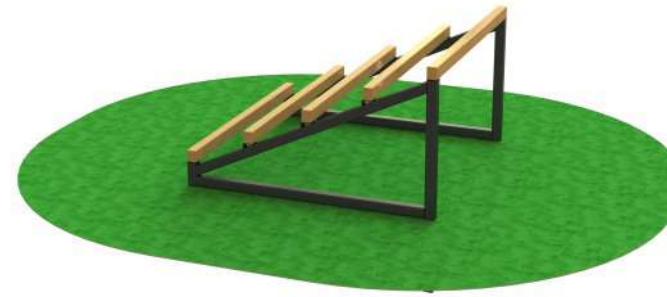

SKU: 20-06829
STEP UP

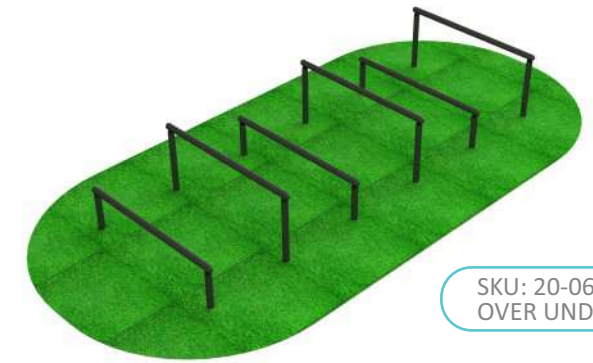

SKU: 20-06759
OVER UNDER



SKU: 20-06826
WALL OR CRAWL

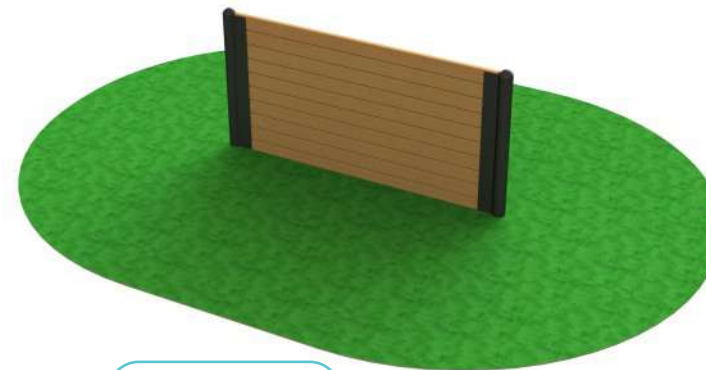

SKU: 20-06825
WALL



SKU: 20-06843
IRISH TABLE

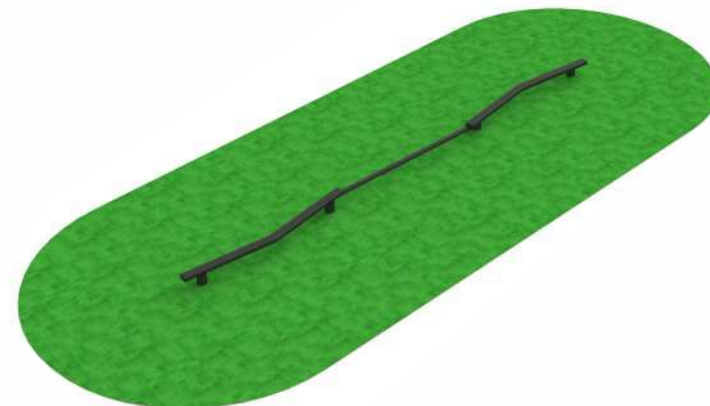

SKU: 20-06855
BALANCE WALK



SKU: 20-06815
DIP WALK



SKU: 20-06827
NET WALL

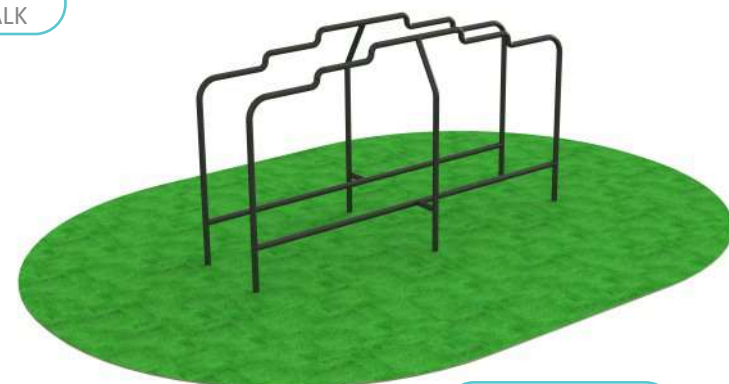

SKU: 20-06850
DIP STEPS



SKU: 20-06863
PEAK



KINGSDOWN SCHOOL



We have worked with our trusted partner OUTDOOR Fitness Concepts to fulfill their vision of a fitness and play area for Kingsdown secondary school outdoor gym.

The new fitness area includes a variety of cardio and calisthenics equipment for people of all ages and skill levels that are intended to promote movement and enhance balance, coordination, strength, and functional conditioning. Moreover, the area has zero operational costs.



GYM FOR PARKS AND TRAILS



SKU: 20-11109
TWISTER



SKU: 20-11113
ROWER



SKU: 20-11101
LEG PRESS



SKU: 20-11107
LEG SWING



SKU: 20-11099
PUSH CHAIR



SKU: 20-10969
PUSH & PULL CHAIR

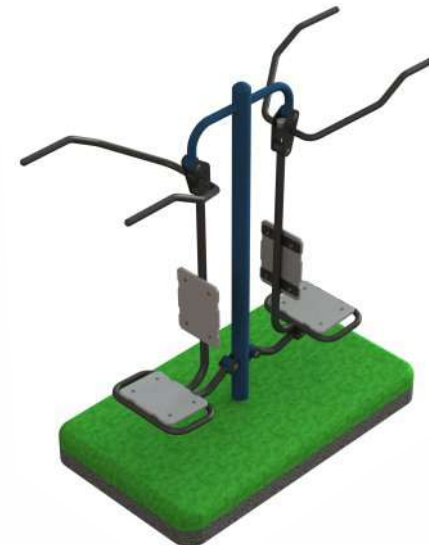

SKU: 20-10977
PULL CHAIR



SKU: 20-11111
AIR WALKER



SKU: 20-11115
CROSS TRAINER



SKU: 20-11105
HIP SWING



SKU: 20-11103
SPINNER

Meeting places and training spots in the yard - for fun and active communication

Every yard should have a place to come with family and friends. Combining various elements of equipment, you can create attractive smart training space, in municipality parks, schools, kindergartens, residential complexes or hotels. Even a small area is not a barrier. We can always suggest ways to design a compact, multipurpose area that seamlessly blends into its surroundings.

Certificate

No. 5.1.22/1176-1/012

We hereby certify that the product - Components and Structures of the playground equipment is in compliance with the requests of standard EN1176-1:2017

Name and address of manufacturer: ELEMENT LAB, LTD
 Štikliju iela 7B, Daugavpils LV-5404, Latvia

Product: Components and Structures of the playground equipment

Type, model: Functional training station

Description and marking of components: Annex 1 (10 pages)

Used standards: EN1176-1:2017 Playground equipment and surfacing. General safety requirements and test methods. EN1177:2018 Impact attenuating playground surfacing. Methods of test for determination of impact attenuation

Report No.: 5.1.22/1176-1/012-TR

Valid until: 19.12.2027.

NOTE: After mounting of the Functional training station, the operator of the station remains responsible for maintaining the suitability for the performance of equipment present. In no event TÜV Rheinland is held liable for damages resulting from poor maintenance or inappropriate use of equipment.

Rīga, 19.12.2022.

Aleksandrs Braslis
 Certification Body of „LRTDEA“ TÜV Rheinland group, LTD

„LRTDEA“ - TÜV Rheinland Group, LTD
 Reg. No. 40003221612
 Katlakalna Street 6a, Rīga, LV-1073, Latvia
 Phone: +371 67568605
 E-mail: toy@tuv.lv
 WEB: http://www.tuv.lv



Certificate

No. 5.1.22/16630/011

We hereby certify that the product - Components and Structures of the outdoor fitness equipment is in compliance with the requests of standard EN16630:2015

Name and address of manufacturer: ELEMENT LAB, SIA
 7B, Štikliju Street, Daugavpils, LV-5404, Latvia

Product: Components and Structures of the outdoor fitness equipment

Type, model: Functional training station

Description and marking of components: Annex 1 (10 pages)

Used standards: EN16630:2015 Permanently installed outdoor fitness equipment. Safety requirements and test methods; EN1176-1:2017 Playground equipment and surfacing. General safety requirements and test methods; EN1177:2018 Impact attenuating playground surfacing. Methods of test for determination of impact attenuation

Report No.: 5.1.22/16630/011-TR

Valid until: 19.12.2027.

NOTE: After mounting of the Functional training station the operator of the station remains responsible for maintaining the suitability for the performance of equipment present. In no event TÜV Rheinland is held liable for damages resulting from poor maintenance or inappropriate use of equipment.





Rīga, 19.12.2022.

Aleksandrs Braslis
 Certification Body of „LRTDEA“ TÜV Rheinland group, LTD

„LRTDEA“ - TÜV Rheinland Group, LTD
 Reg. No. 40003221612
 Katlakalna Street 6a, Rīga, LV-1073, Latvia
 Phone: +371 67568605
 E-mail: toy@tuv.lv
 WEB: http://www.tuv.lv





 **Element Fitness**[®]
 Stiklu street 7B, Daugavpils, LATVIA
 +371 22029009
 info@elementfitness.eu
 www.elementfitness.eu

element[®]
FITNESS

we bring the solution to your challenge

 @elementfts