

**SKY Master**®  
**Professional**

Catálogo de Automação Residencial e Industrial  
/ Catálogo de Automación Residencial y Industrial  
/ Catalogue d'Automation Résidentielle et Industrielle  
/ Automation Catalogue for Home and Industry

# Tienda Online



DAPORTAS es distribuidor oficial de SkyMaster para la Península Ibérica. Puede comprar equipos y accesorios de SkyMaster en nuestra Tienda Online y recibirlos cómodamente en su hogar en un plazo de hasta 5 días laborables. DAPORTAS es la Tienda Online de automatismos N°1 en Europa.

DAPORTAS és distribuïdor oficial de SkyMaster per a la Península Ibèrica. Pots comprar equips i accessoris de SkyMaster a la nostra Botiga Online i rebre'ls còmodament a casa teva en un termini de fins a 5 dies laborables. DAPORTAS és la Botiga Online d'automatismes N°1 a Europa.

DAPORTAS é distribuidor oficial de SkyMaster para a Península Ibérica. Pode mercar equipos e accesorios de SkyMaster na nosa Tenda Online e recibilos comodamente na súa casa nun prazo de ata 5 días hábiles. DAPORTAS é a Tenda Online de automatismos N°1 en Europa.

DAPORTAS SkyMaster-ren banatzaile ofiziala da Iberiar Penintsulan. SkyMaster ekipamenduak eta osagarriak gure Online Dendan eros ditzakezu, eta zure etxean eroso jaso, gehienez 5 laneguneko epean. DAPORTAS Europako 1. zenbakiko automatismoen Online Denda da.

**MOTOR PARA PORTÕES DE CORRER**  
MOTOR DE PUERTAS CORREDERAS  
MOTEUR POUR PORTES COULISSANTES  
SLIDING GATES OPERATOR



03 - 07

**MOTOR PARA PORTÕES DE BATENTES**  
MOTOR DE PUERTAS DE BATIENTES  
MOTEUR POUR PORTES BATTANTES  
SWING GATES OPERATOR



09 - 17

**MOTOR PARA PORTÕES SECCIONADOS**  
MOTOR DE PUERTAS SECCIONALES  
MOTEUR POUR PORTES SECTIONNELLES  
SECTIONAL DOORS OPERATOR



19 - 27

**MOTOR PARA PORTÕES SECCIONADOS INDUSTRIAIS**  
MOTOR DE PUERTAS SECCIONALES INDUSTRIALES  
MOTEUR POUR PORTES SECTIONNELLES INDUSTRIELLES  
INDUSTRIAL SECTIONAL DOORS OPERATOR

29 - 33

**MOTOR PARA ESTORES E GRADES DE ENROLAR**  
MOTOR PARA PERSIANAS Y PUERTAS ENROLLABLES  
MOTEUR POUR STORES ET PORTES ENROULABLES  
ROLLING SHUTTERS OPERATOR



35 - 39

**MOTOR PARA GRADES DE ENROLAR INDUSTRIAIS**  
MOTOR PARA PUERTAS ENROLLABLES INDUSTRIALES  
MOTEUR POUR PORTES ENROULABLES INDUSTRIELLES  
INDUSTRIAL ROLLING SHUTTERS OPERATOR

41 - 45

**BARREIRAS AUTOMÁTICAS**  
BARRERAS AUTOMATICAS  
BARRIÈRES AUTOMATIQUES  
PARKING BARRIER GATES



47 - 51

**ACESSÓRIOS E QUADROS DE CONTROLO**  
ACCESORIOS Y CUADROS DE MANDO  
ACCESSOIRES ET CARTES DE CONTRÔLE  
ACCESSORIES AND CONTROL CARDS

52 - 63



# F-500

# F-550

MOTOR PARA PORTÕES DE CORRER  
MOTOR DE PUERTAS CORREDERAS  
MOTEUR POUR PORTES COULISSANTES  
SLIDING GATES OPERATOR

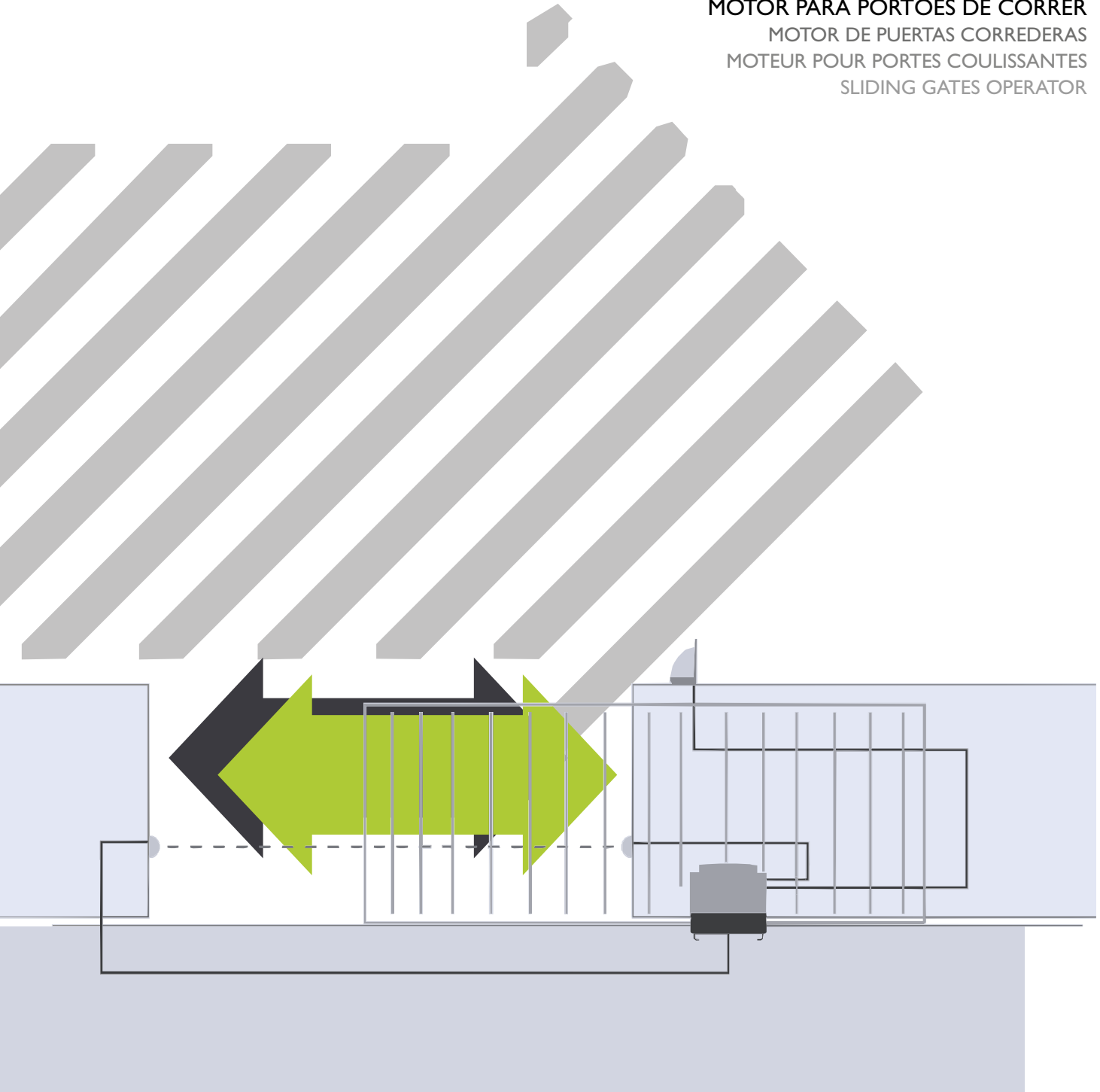

MOTOR DE CORRER  
MOTOR DE CORREDERA  
MOTEUR COULISSANT  
SLIDING GATE OPENER

# F-550



CE

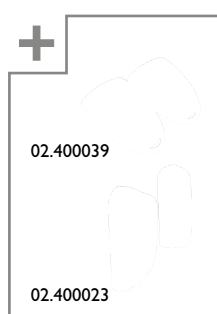
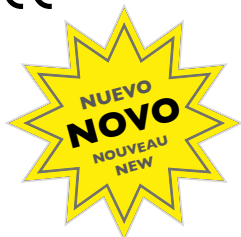

Alimentação / Alimentación / Alimentation / Power supply	V AC	230
Motor / Motor / Moteur / Motor	V DC	24
Potência / Potencia / Puissance / Power	W	110
Torque / Torque / Moment de force / Torque	N.m	300
Tracção / Tracción / Traction / Traction	Pinhão-Cremalheira / Piñon-Cremallera / Pignon-Crémaillère / Pinion-Rack	Z15 - M4
Peso máx. / Peso máx. / Poids max. / Max. weight	Kg	600
Largura máx. / Anchura máx. / Longueur max. / Max. length	m	8
Velocidade / Velocidad / Vitesse / Speed	cm/s	16.0
Protecção térmica / Protección térmica / Protection thermique / Thermal protection	°C	110
Temperatura / Temperatura / Temperature / Temperature	°C	-25 ~ +50
Índice de protecção / Índice de protección / Indice de protection / IP Code	(IEC 60529)	IP 44
Placa de controlo / Central de mando / Logique de commande / Control card	SKCR-1A integrada / integrada / intégrée / integrated	

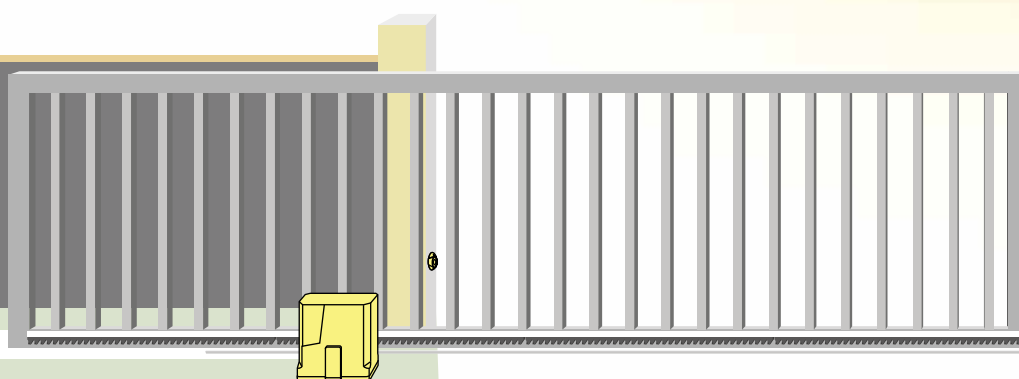

Motor para portões de correr. O mais económico da sua gama  
 / Motor para puertas correderas. El más bajo consumo de su gama  
 / Moteur pour portes coulissantes. Le plus économique de sa série  
 / Sliding gate operator. The most power-efficient of its series

Operação muito silenciosa  
 / Funcionamiento muy silencioso  
 / Fonctionnement très silencieux  
 / Very quiet operation



Fins de curso mecânicos  
 / Finales de carrera mecánicas  
 / Fins de course mécaniques  
 / Mechanical limit switches

Desbloqueio de emergência manual  
 / Desbloqueo manual de emergencia  
 / Débrayage manuel d'urgence  
 / Emergency manual declutch

Placa integrada e espaço para bateria de emergência  
 / Cuadro integrado y espacio para batería de emergencia  
 / Carte logique intégrée et d'espace pour batterie de secours  
 / Integrated control board and space for emergency battery

Sensibilidade a pequenos obstáculos com inversão automática  
 / Sensibilidad a pequeños obstáculos con inversión automática  
 / Sensibilité aux petits obstacles avec inversion automatique  
 / Sensitivity to small obstacles with automatic reversal

Abertura total ou pedonal com abrandamento  
 / Apertura total o peatonal con deceleración  
 / Ouverture complète ou piétonne avec ralentissement  
 / Total or pedestrian only opening with deceleration

Função 2 folhas integrada  
 / Función 2 hojas integrada  
 / Fonction 2 vantaux intégrés  
 / 2 leaves function integrated

Kit motor / Kit motor / Kit moteur / Operator's kit



**Kit F-550** 02.440206

Motor / Motor / Moteur / Operator

Com placa de controlo / Avec logique de commande  
 Con central de mando / With control board

**F-550** 02.440306

#### Outros acessórios

/ Otros accesorios  
 / Autres accessoires  
 / Other accessories

**Emissor 'Black+Inox' 4 canais** 02.400039

Mando 'Black+Inox' 4 canales  
 Émetteur 'Black+Inox' 4 canaux  
 Emitter 'Black+Inox' 4 channels

**Botoneira de parede sem-fios** 02.400002

Mando de pared inalámbrico  
 Bouton mural sans fil  
 Wireless push button station

**Selector de chave** 02.600904

Selector de llave  
 Sélecteur à clé  
 Keyswitch

**Selector digital sem fios** 02.400018

Teclado digital inalámbrico  
 Clavier numérique sans fil  
 Wireless digital keypad

**Fotocélulas de parede** 02.400023

Fotocélulas de pared  
 Photocellules murales  
 Surface mount photocells

**Pirillampo 230V com antena** 02.400010

Lámpara de destellos 230V con antena  
 Feu clignotant 230V avec antenne  
 Flashing light 230V with antenna

**Receptor externo 4 canais** 02.400013

Receptor externo 4 canales  
 Récepteur externe 4 canaux  
 External receiver 4 channels

**Receptor de longo alcance, 2 canais** 02.400021

Receptor de largo alcance, 2 canales  
 Récepteur longue portée, 2 canaux  
 Long range receiver, 2 channels

Cremalheira para motor / Cremallera para motor / Crémaillère pour moteur / Opening rack

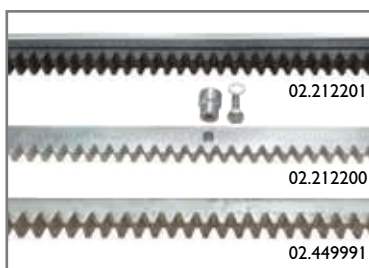

**Cremalheira de nylon** 02.212201

Cremallera de nylon  
 Crémaillère de nylon  
 Nylon rack 22x52x1000mm

**Cremalheira de ferro, aparafusar** 02.212200

Cremallera de hierro, atornillar  
 Crémaillère de fer, visser  
 Steel rack, screw-type 12x32x1000mm

**Cremalheira de ferro, soldar** 02.449991

Cremallera de hierro, soldar  
 Crémaillère de fer, souder  
 Steel rack, weld-type 22x22x2000mm

MOTOR DE CORRER  
MOTOR DE CORREDERA  
MOTEUR COULISSANT  
SLIDING GATE OPENER

# F-500

230v

1600  
Kg



CE

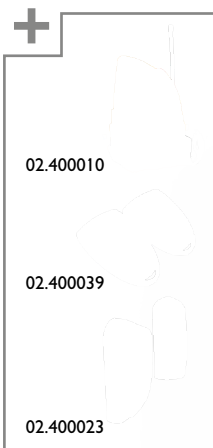

**SKY Master**  
Professional

		F-500A	F-500B	F-500G
Potência / Potencia / Puissance / Power	W	200	250	350
Tensão / Voltaje / Tension / Voltage	VAC	220	220	220
Intensidade / Absorción / Intensité / Absorption	A	1.15	0.92	0.65
Tracção / Tracción / Traction / Traktion	Pinhão-Cremalheira / Piñon-Cremallera / Pignon-Crémaillère / Pinion-Rack	Z15 - M4	Z15 - M4	Z15 - M4
Velocidade / Velocidad / Vitesse / Speed	m/min.	11.5	11.5	11.5
Peso máx. / Peso máx. / Poids max./ Max. weight	Kg	400	800	1600
Largura máx. / Anchura máx. / Longueur max. / Max. length	m	12	12	12
Ciclos / Ciclos / Cycles / Cycles	X/h	20	20	20
Temperatura / Temperatura / Temperature / Temperature	°C	-20 ~ +40	-20 ~ +40	-20 ~ +40
Fusível / Fusible / Fusible / Fuse	A	5	5	5
Placa de controlo / Central de mando / Logique de commande / Control card		SKCR-1C integrada / integrada / intégrée / integrated		

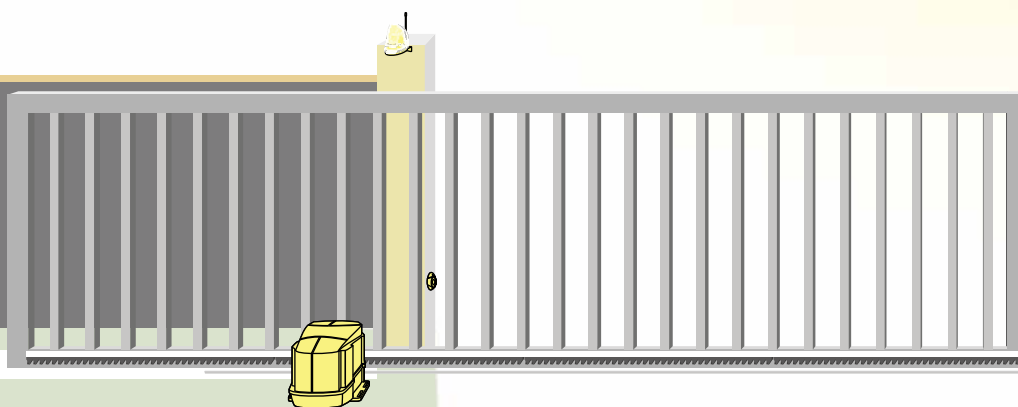

Motor para portões de correr de pequeno a grande porte, muito fácil de instalar  
 / Motor para puertas correderas de pequeños a grandes tamaños, muy fácil de instalar  
 / Moteur pour portes coulissantes de petite à grande taille, très facile à installer  
 / Sliding gates' operator from small to large size, very easy to install

Sensibilidade a pequenos obstáculos com inversão automática  
 / Sensibilidad a pequeños obstáculos con inversión automática  
 / Sensibilité aux petits obstacles avec inversion automatique  
 / Sensitivity to small obstacles with automatic reversal



**Operação muito silenciosa**  
 / Funcionamiento muy silencioso  
 / Fonctionnement très silencieux  
 / Very uiet operation

**Fins de curso mecânicos**  
 / Finales de carrera mecánicos  
 / Fins de course mécaniques  
 / Mechanical limit switches

**Desbloqueio de emergência manual**  
 / Desbloqueo manual de emergencia  
 / Débrayage manuel d'urgence  
 / Emergency manual declutch

**Placa integrada com microprocessador inteligente**  
 / Cuadro integrado con microprocesador inteligente  
 / Carte logique intégrée à microprocesseur  
 / Integrated microprocessed smartcard

**Abertura total ou pedonal com abrandamento**  
 / Apertura total o peatonal con deceleración  
 / Ouverture complète ou piétonne avec ralentissement  
 / Total or pedestrian only opening with deceleration

**Codificação Rolling Code anti-cópia**  
 / Codificación Rolling Code anticopia  
 / Codage Rolling Code anti-copie  
 / Anti-copy Rolling Code coding

Kit motor / Kit motor / Kit moteur / Operator's kit



<b>Kit F-500A</b>	02.440204
<b>Kit F-500B</b>	02.440208
<b>Kit F-500G</b>	02.440216

Motor / Motor / Moteur / Operator

<b>F-500A</b>	02.440304
<b>F-500B</b>	02.440308
<b>F-500G</b>	02.440316

**Outros acessórios**

/ Otros accesorios  
 / Autres accessoires  
 / Other accessories

<b>Emissor 'Black+Inox' 4 canais</b> Mando 'Black+Inox' 4 canales Émetteur 'Black+Inox' 4 canaux Emitter 'Black+Inox' 4 channels	02.400039
<b>Botoneira de parede sem-fios</b> Mando de pared inalámbrico Bouton mural sans fil Wireless push button station	02.400002
<b>Selector de chave</b> Selector de llave Sélecteur à clé Keyswitch	02.270213
<b>Selector digital sem fios</b> Teclado digital inalámbrico Clavier numérique sans fil Wireless digital keypad	02.400018
<b>Fotocélulas de parede</b> Fotocélulas de pared Photocellules murales Surface mount photocells	02.400023
<b>Receptor externo 4 canais</b> Receptor externo 4 canales Récepteur externe 4 canaux External receiver 4 channels	02.400013
<b>Receptor de longo alcance, 2 canais</b> Receptor de largo alcance, 2 canales Récepteur longue portée, 2 canaux Long range receiver, 2 channels	02.400021

Cremalheira para motor / Cremallera para motor / Crémaillère pour moteur / Opening rack

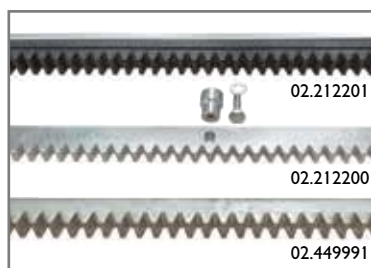

<b>Cremalheira de nylon</b> Cremallera de nylon Crémaillère de nylon Nylon rack	02.212201 22x52x1000mm
<b>Cremalheira de ferro, aparafusar</b> Cremallera de hierro, atornillar Crémaillère de fer, visser Steel rack, screw-type	02.212200 12x32x1000mm
<b>Cremalheira de ferro, soldar</b> Cremallera de hierro, soldar Crémaillère de fer, souder Steel rack, weld-type	02.449991 22x22x2000mm



# SK350 SK4/SK6 SK300 STEER

MOTOR PARA PORTÕES DE BATENTES  
MOTOR DE PUERTAS DE BATIENTES  
MOTEUR POUR PORTES BATTANTES  
SWING GATES OPERATOR

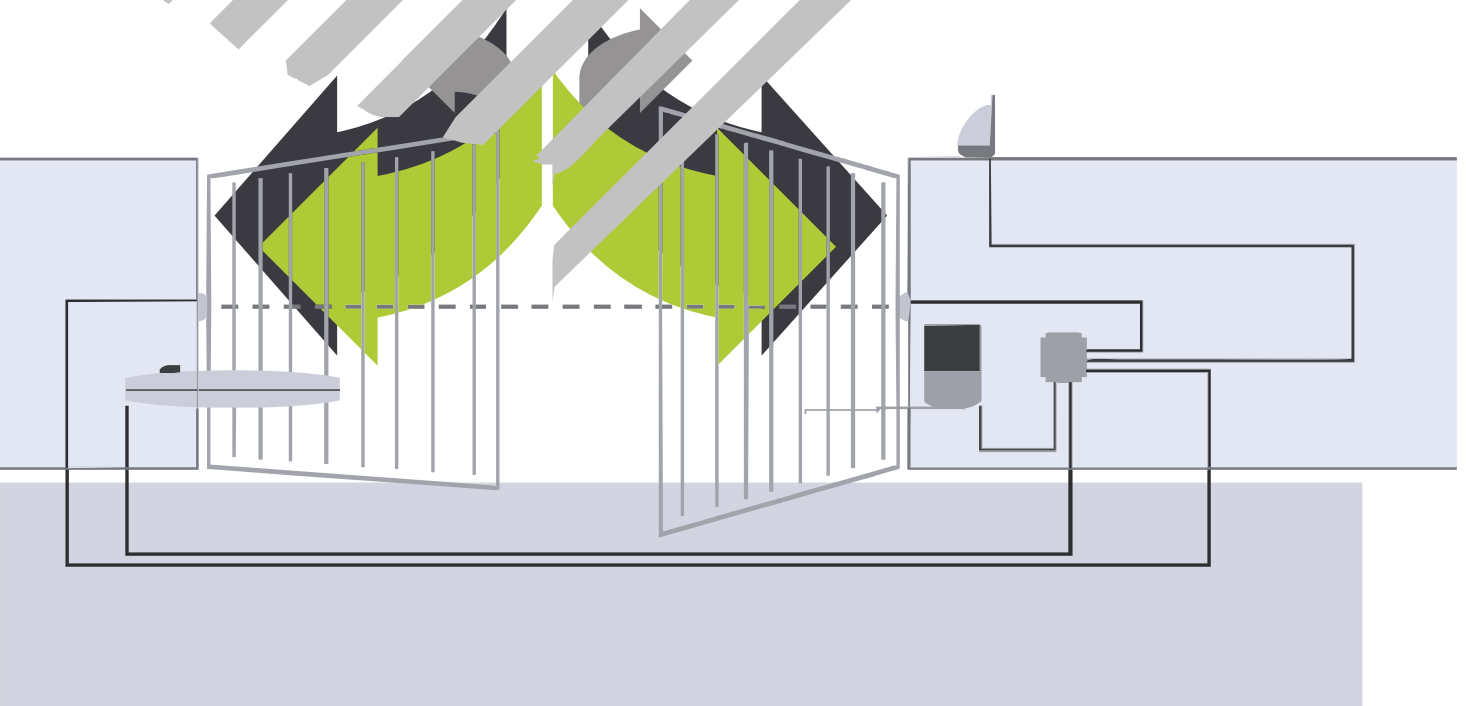

MOTOR DE BATENTE  
 MOTOR PARA BATIENTES  
 MOTEUR POUR BATTANTES  
 SWING GATE OPERATOR

# SK350



CE



Tensão / Voltaje / Tension / Voltage	V DC	24
Potência / Potencia / Puissance / Power	W	100
Intensidade / Absorción / Intensité / Absorption	A	3.8
Curso máx. / Carrera máx. / Course max. / Max. course	mm	350
Peso máx. / Peso máx. / Poids max. / Max. weight	Kg	350
Largura máx. / Anchura máx. / Largeur max. / Max. length	m	2.5
Ciclos / Ciclos / Cycles / Cycles	X/h	50
Índice de protecção / Índice de protección / Indice de protection / IP Code	(IEC 60529)	IP 24
Temperatura / Temperatura / Température / Temperature	°C	-20 ~ +50
Placa de controlo / Central de mando / Logique de commande / Control card	SkyMaster SKBT-24	

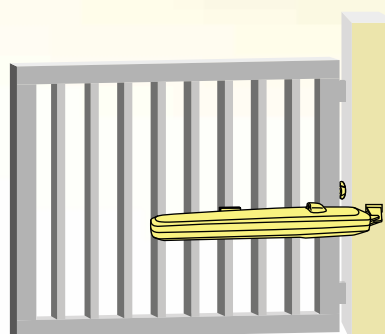
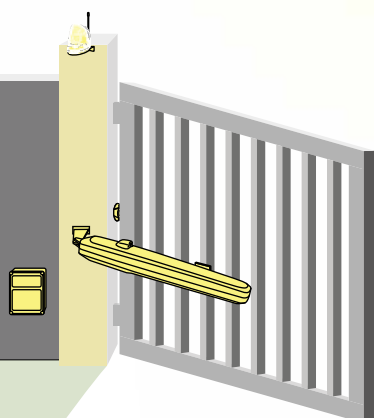

O motor mais compacto para portões de batentes, de 1 ou 2 folhas  
 / El motor más compacto para puertas de batientes, con 1 o 2 hojas  
 / Le moteur plus compact pour portes battantes de 1 ou 2 vantaux  
 / The most compact swing door operator, for 1 or 2 leaves

Sensibilidade a pequenos obstáculos com inversão automática  
 / Sensibilidad a pequeños obstáculos con inversión automática  
 / Sensibilité aux petits obstacles avec inversion automatique  
 / Sensitivity to small obstacles with automatic reversal

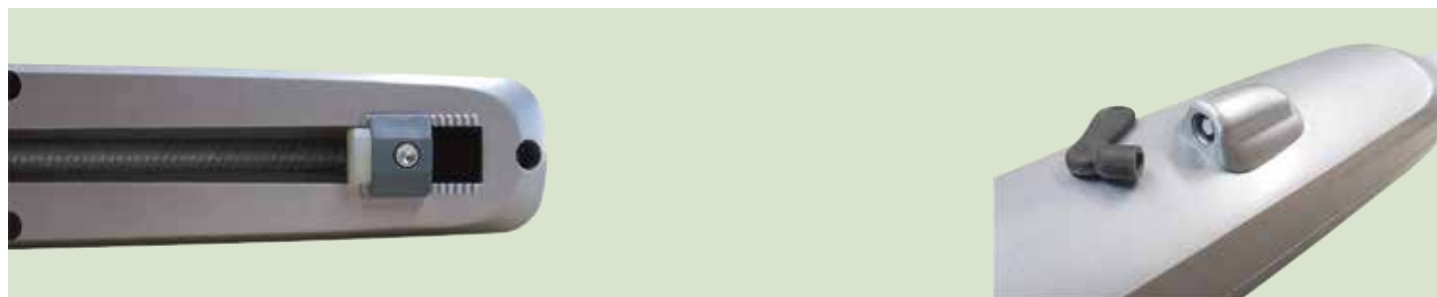

Velocidade programável e controlo de trinco eléctrico  
 / Velocidad programable y control de cerradura eléctrica  
 / Vitesse programmable et contrôle de verrou électrique  
 / Programmable speed and electric latch control

Fins de curso mecânicos  
 / Finales de carrera mecánicas  
 / Fins de course mécaniques  
 / Mechanical limit switches

Desbloqueio de emergência manual  
 / Desbloqueo manual de emergencia  
 / Débrayage manuel d'urgence  
 / Emergency manual declutch

Abertura da folha até 120°  
 / Apertura de la hoja hasta 120°  
 / Ouverture de la vantail jusqu'à 120°  
 / Opening range of the leaf up to 120°

Abertura total ou pedonal com abrandamento  
 / Apertura total o peatonal con deceleración  
 / Ouverture complète ou piétonne avec ralentissement  
 / Total or pedestrian only opening with deceleration

Codificação Rolling Code anti-cópia  
 / Codificación Rolling Code anticopia  
 / Codage Rolling Code anti-copie  
 / Anti-copy Rolling Code coding

Kit motor / Kit motor / Kit moteur / Operator's kit



**Kit SK350** 1 folha 02.427210  
 1 hoja  
 1 vantail  
 1 leaf

**Kit SK350** 2 folha 02.427220  
 2 hojas  
 2 vantaux  
 2 leaves

Motor / Motor / Moteur / Operator

**SK350** (1 motor) 02.427310  
 (1 motor)  
 (1 moteur)  
 (1 operator)

#### Outros acessórios

/ Otros accesorios  
 / Autres accessoires  
 / Other accessories

**Fechadura eléctrica vertical** 12V 02.276011  
 Cerradura eléctrica vertical  
 Serrure électrique verticale  
 Electrical vertical lock

**Bateria de emergência** 12V/7A 02.400012  
 Bateria de emergencia  
 Batterie de secours  
 Emergency battery

**Emissor 'Black+Inox' 4 canais** 02.400039  
 Mando 'Black+Inox' 4 canales  
 Émetteur 'Black+Inox' 4 canaux  
 Emitter 'Black+Inox' 4 channels

**Botoneira de parede sem-fios** 02.400002  
 Mando de pared inalámbrico  
 Bouton mural sans fil  
 Wireless push button station

**Selector de chave** 02.270213  
 Selector de llave  
 Sélecteur à clé  
 Keyswitch

**Selector digital sem fios** 02.400018  
 Teclado digital inalámbrico  
 Clavier numérique sans fil  
 Wireless digital keypad

**Receptor de longo alcance, 2 canais** 02.400021  
 Receptor de largo alcance, 2 canales  
 Récepteur longue portée, 2 canaux  
 Long range receiver, 2 channels

**Fotocélulas de parede** 02.400023  
 Focélulas de pared  
 Photocellules murales  
 Surface mount photocells

Outros quadros de controlo / Otros cuadros de maniobras  
 / Autres logiques de commande / Other control boards

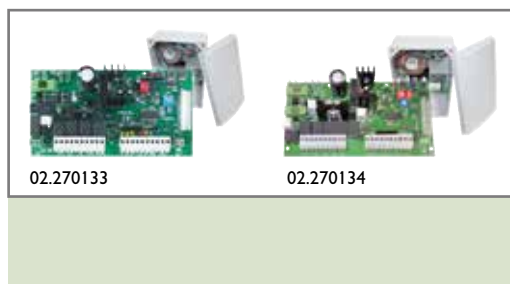

02.270133

02.270134

**CTR33** para 1 folha 02.270133  
 para 1 hoja  
 pour 1 vantail  
 for 1 leaf

**CTR34** para 2 folhas 02.270134  
 para 2 hojas  
 pour 2 vantaux  
 for 2 leaves

**Caixa isolante em PVC** 02.400219  
 Caja aislante de PVC  
 Boîte isolante en PVC  
 PVC insulating box

MOTOR DE BATENTE  
MOTOR PARA BATIENTES  
MOTEUR POUR BATTANTES  
SWING GATE OPERATOR

# SK4/SK6



CE

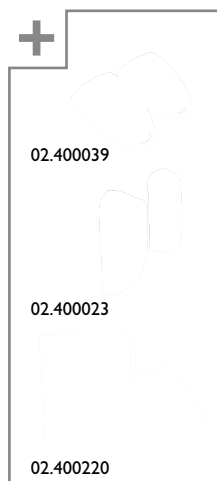

SK4

SK6

Tensão / Voltaje / Tension / Voltage	V AC	230	230
Potência / Potencia / Puissance / Power	W	280	280
Intensidade / Absorción / Intensité / Absorption	A	1.7	1.7
Torque / Torque / Moment de force / Torque	N.m	1800	1800
Curso máx. / Carrera máx. / Course max. / Max. course	mm	400	600
Velocidade / Velocidad / Vitesse / Speed	cm/s	2.0	2.0
Peso máx. / Peso máx. / Poids max. / Max. weight	Kg	250	250
Largura máx. / Anchura máx. / Largeur max. / Max. length	m	2.5	3.5
Ciclos consecutivos / Ciclos consecutivos / Cycles consécutifs / Consecutive cycles	X	11	11
Índice de protecção / Índice de protección / Indice de protection / IP Code	(IEC 60529)	IP 54	IP 54
Temperatura / Temperatura / Température / Temperature	°C	-20 ~ +70	-20 ~ +70
Placa de controlo / Central de mando / Logique de commande / Control card	SkyMaster SKBT-230		

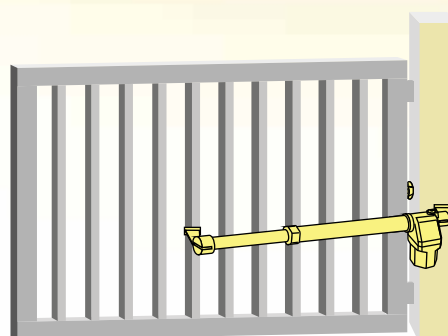
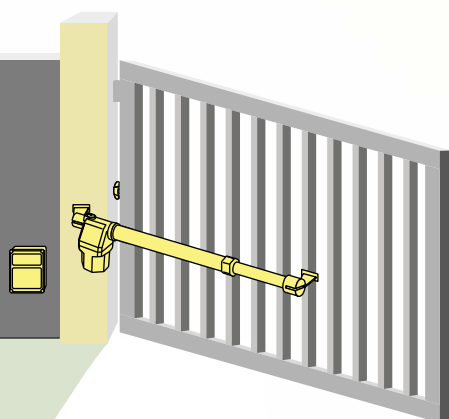

**Motor para portões de batentes, de 1 ou 2 folhas. A solução mais robusta**  
 / Motor para puertas de batientes de una o dos hojas. La solución más robusta  
 / Moteur pour portes battantes d'un ou deux vantaux. La solution plus robuste  
 / Swing gate operator, for one or two leaves. The most powerful solution

**Programação independente das folhas**  
 / Programación independiente de las hojas  
 / Programmation indépendante des vantaux  
 / Independent programming of the leaves



**Tracção por 'sem-fim' em aço temperado e braço em inox**  
 / Tracción por 'sin fin' de acero templado y brazo de inox  
 / Traction par 'sans fin' en acier trempé et bras en inox  
 / Traction by hardened steel worm gear and stainless steel arm

**Protecção térmica**  
 / Protección térmica  
 / Protection thermique  
 / Thermal protection

**Desbloqueio de emergência manual**  
 / Desbloqueo manual de emergencia  
 / Débrayage manuel d'urgence  
 / Emergency manual declutch

**Acabamento em epoxi anticorrosivo**  
 / Acabado epoxi anticorrosivo  
 / Finition époxy anticorrosion  
 / Anticorrosive epoxy finish

**Abertura da folha até 120° e abrandamento**  
 / Apertura de la hoja hasta 120° y desaceleración  
 / Ouverture des vantaux jusqu'à 120° et ralentissement  
 / Opening range of leaf up to 120° and deceleration

**Codificação Rolling Code anti-cópia**  
 / Codificación Rolling Code anticopia  
 / Codage Rolling Code anti-copie  
 / Anti-copy Rolling Code coding

Kit motor / Kit motor / Kit moteur / Operator's kit



**Kit SK4** 2 folhas 02.424021  
 2 hojas  
 2 vantaux  
 2 leaves

**Kit SK4** 1 folha, esquerdo 02.424015  
 1 hoja, izquierdo  
 1 vantail, gauche  
 1 leaf, left

**Kit SK4** 1 folha, direito 02.424010  
 1 hoja, derecho  
 1 vantail, droite  
 1 leaf, right

**Kit SK6** 2 folhas 02.426021  
 2 hojas  
 2 vantaux  
 2 leaves

**Kit SK6** 1 folha, esquerdo 02.426015  
 1 hoja, izquierdo  
 1 vantail, gauche  
 1 leaf, left

**Kit SK6** 1 folha, direito 02.426010  
 1 hoja, derecho  
 1 vantail, droite  
 1 leaf, right

Motor / Motor / Moteur / Operator

**SK4** esquerdo (1 motor) 02.424095  
 izquierdo (1 motor)  
 gauche (1 moteur)  
 left (1 operator)

**SK4** direito (1 motor) 02.424090  
 derecho (1 motor)  
 droite (1 moteur)  
 right (1 operator)

**SK6** esquerdo (1 motor) 02.426095  
 izquierdo (1 motor)  
 gauche (1 moteur)  
 left (1 operator)

**SK6** direito (1 motor) 02.426090  
 derecho (1 motor)  
 droite (1 moteur)  
 right (1 operator)



**Fechadura eléctrica vertical**  
 Cerradura eléctrica vertical  
 Serrure électrique verticale  
 Electrical vertical lock  
 12V

**Outros acessórios**

/ Otros accesorios  
 / Autres accessoires  
 / Other accessories

**Fechadura eléctrica vertical** 12V 02.276011  
 Cerradura eléctrica vertical  
 Serrure électrique verticale  
 Electrical vertical lock

**Fotocélulas de parede** 02.400023  
 Fococélulas de pared  
 Photocellules murales  
 Surface mount photocells

**Pirilampo 230V com antena** 02.400010  
 Lámpara de destellos 230V con antena  
 Feu clignotant 230V avec antenne  
 Flashing light 230V with antenna

**Selector de chave** 02.270213  
 Selector de llave  
 Sélecteur à clé  
 Keyswitch

MOTOR ARTICULADO DE BATENTE  
 MOTOR ARTICULADO PARA BATTIENTES  
 MOTEUR ARTICULÉ POUR BATTANTES  
 ARTICULATED ARM FOR SWING GATE

# SK300



CE



Tensão / Voltaje / Tension / Voltage	V DC	24
Potência / Potencia / Puissance / Power	W	40
Intensidade / Absorción / Intensité / Absorption	A	2.0
Velocidade / Velocidad / Vitesse / Speed	rpm	1800
Largura máx. / Anchura máx. / Largeur max. / Max. length	m	3
Peso máx. / Peso máx. / Poids max. / Max. weight	Kg	300
Tempo de trabalho / Tiempo de trabajo / Temps de travail / Working cycle	min.	5
Índice de protecção / Índice de protección / Indice de protection / IP Code	(IEC 60529)	IP 44
Temperatura / Temperatura / Température / Temperature	°C	-20 ~ +50
Placa de controlo / Central de mando / Logique de commande / Control card	SkyMaster SKBT-24	

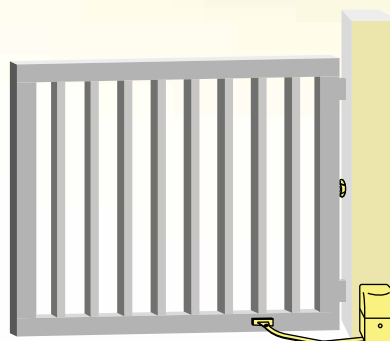
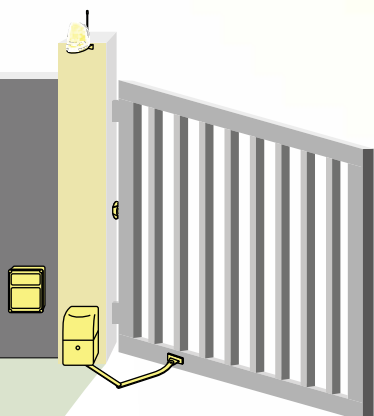

Motor para portões de batentes, muito versátil em aplicações atípicas  
 / Motor para puertas de batientes, versátil en las aplicaciones más exigentes  
 / Moteur pour portes battantes, polyvalent dans les applications les plus exigeantes  
 / Swing door operator, the most versatile in atypical applications

Sensibilidade a pequenos obstáculos com inversão automática  
 / Sensibilidad a pequeños obstáculos con inversión automática  
 / Sensibilité aux petits obstacles avec inversion automatique  
 / Sensitivity to small obstacles with automatic reversal



Possibilidade de abertura para o exterior  
 / Posibilidad de apertura hacia el exterior  
 / Possibilité d'ouverture vers l'extérieur  
 / Possibility of opening to the outside

Abertura total ou pedonal com abrandamento  
 / Apertura total o peatonal con deceleración  
 / Ouverture complète ou piétonne avec ralentissement  
 / Total or pedestrian-only opening with deceleration

Desbloqueio manual de emergência  
 / Desbloqueo manual de emergencia  
 / Débrayage manuel d'urgence  
 / Emergency manual declutch

Velocidade programável e controlo de trinco eléctrico  
 / Velocidad programable y control de cierre eléctrico  
 / Vitesse programmable et contrôle de verrou électrique  
 / Programmable speed and electric latch control

Fins de curso mecânicos  
 / Finales de carrera mecánicas  
 / Fins de course mécaniques  
 / Mechanical limit switches

Codificação Rolling Code anti-cópia  
 / Codificación Rolling Code anticopia  
 / Codage Rolling Code anti-copie  
 / Anti-copy Rolling Code coding

Kit motor / Kit motor / Kit moteur / Operator's kit



Kit **SK300** 1 folha 02.428210  
 1 hoja  
 1 vantail  
 1 leaf

Kit **SK300** 2 folha 02.428220  
 2 hojas  
 2 vantaux  
 2 leaves

Motor / Motor / Moteur / Operator

**SK300** (1 motor) 02.428310  
 (1 motor)  
 (1 moteur)  
 (1 operator)

Outros quadros de controlo / Otros cuadros de maniobras  
 / Autres cadres de commande / Other control boards

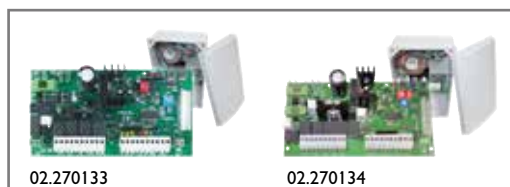

02.270133

02.270134

CTR33 para 1 folha 02.270133  
 para 1 hoja  
 pour 1 vantail  
 for 1 leaf

CTR34 para 2 folhas 02.270134  
 para 2 hojas  
 pour 2 vantaux  
 for 2 leaves

Caixa isolante em PVC 02.400219  
 Caja aislante de PVC  
 Boîte isolante en PVC  
 PVC insulating box

Outros acessórios

/ Otros accesorios  
 / Autres accessoires  
 / Other accessories

Fechadura eléctrica vertical 12V 02.276011  
 Cerradura eléctrica vertical  
 Serrure électrique verticale  
 Electrical vertical lock

Bateria de emergência 12V/7A 02.400012  
 Bateria de emergencia  
 Batterie de secours  
 Emergency battery

Emissor 'Black+Inox' 4 canais 02.400039  
 Mando 'Black+Inox' 4 canales  
 Émetteur 'Black+Inox' 4 canaux  
 Emitter 'Black+Inox' 4 channels

Botoneira de parede sem-fios 02.400002  
 Mando de pared inalámbrico  
 Bouton mural sans fil  
 Wireless push button station

Selector de chave 02.270213  
 Selector de llave  
 Sélecteur à clé  
 Keyswitch

Selector digital sem fios 02.400018  
 Teclado digital inalámbrico  
 Clavier numérique sans fil  
 Wireless digital keypad

Receptor de longo alcance, 2 canais 02.400021  
 Receptor de largo alcance, 2 canales  
 Récepteur longue portée, 2 canaux  
 Long range receiver, 2 channels

Fotocélulas de parede 02.400023  
 Fotocélulas de pared  
 Photocellules murales  
 Surface mount photocells

MOTOR DE ENTERRAR PARA BATENTE  
 MOTOR ENTERRADO PARA BATIENTES  
 MOTEUR ENTERRÉ POUR BATTANTES  
 SWING GATE UNDERGROUND OPERATOR

# STEER

**230v** **550 Kg** **180°** **Heavy duty**

CE



**SKY Master**<sup>®</sup>  
**Professional**

Tensão / Voltaje / Tension / Voltage	V AC	230
Potência / Potencia / Puissance / Power	W	280
Intensidade / Absorción / Intensité / Absorption	A	1.6
Torque / Torque / Moment de force / Torque	N.m	450
Curso máx. / Carrera máx. / Course max. / Max. course	ang. (°)	90/110/180
Velocidade / Velocidad / Vitesse / Speed	rpm	1.0
Peso máx. / Peso máx. / Poids max. / Max. weight	Kg	550
Ciclo de trabalho / Ciclo de trabajo / Rapport cyclique / Duty cycle	%	85
Protecção térmica / Protección térmica / Protection thermique / Thermal protection	°C	150
Índice de protecção / Índice de protección / Indice de protection / IP Code	(IEC 60529)	IP 68
Temperatura / Temperatura / Température / Temperature	°C	-25 ~ +70
Placa de controlo / Central de mando / Logique de commande / Control card	SkyMaster SKBT-230	

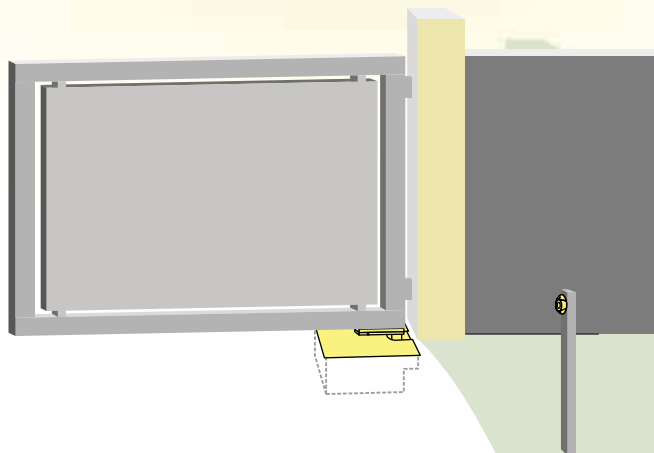
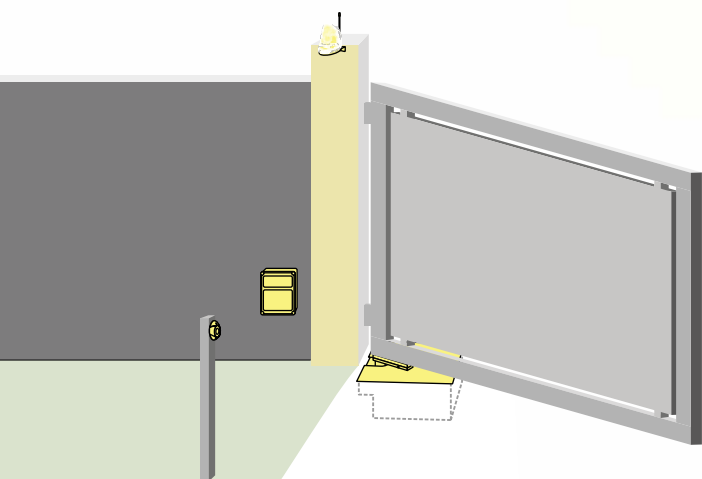

Motorreductor de enterrar para portões de batentes, de 1 ou 2 folhas  
 / Motorreductor enterrado para puertas abatibles de una o dos hojas  
 / Moto réducteur enterré pour portails battants d'un ou deux vantaux  
 / Underground gear motor for one or two leaves swing gate

Após instalação, o motor fica praticamente invisível  
 / Después de la instalación, el motor es prácticamente invisible  
 / Après l'installation, le moteur est pratiquement invisible  
 / After installation, the motor is virtually invisible



Redutora de aço temperado e bronze, em banho de óleo  
 / Transmisión de acero templado y bronce, con baño de aceite  
 / Démultiplicateur d'acier trempé et bronze, dans bains d'huile  
 / Gearbox of hardened steel and brass, oil bathed

Abertura total ou pedonal com abrandamento  
 / Apertura total o peatonal con deceleración  
 / Ouverture complète ou piétonne avec ralentissement  
 / Total or pedestrian only opening with deceleration



Desbloqueio de emergência manual, de ambos os lados da folha  
 / Desbloqueo manual de emergencia, de las dos caras de la hoja  
 / Débrayage manuel d'urgence, des deux côtés du vantail  
 / Emergency manual declutch, from both sides of the leaf

Abertura da folha de 90° a 180°  
 / Apertura de la hoja de 90° hasta 180°  
 / Ouverture du vantail de 90° à 180°  
 / Leaf opening range from 90° to 180°

Codificação Rolling Code anti-cópia  
 / Codificación Rolling Code anticopia  
 / Codage Rolling Code anti-copie  
 / Anti-copy Rolling Code coding

Kit motor / Kit motor / Kit moteur / Operator's kit



Sistema 90°/110° / Système 90°/110°  
 Sistema 90°/110° / 90°/110° System



Sistema 180° / Système 180°  
 Sistema 180° / 180° System

Abertura a 90°/110° / Ouverture a 90°/110°  
 Apertura a 90°/110° / 90°/110° opening

**Kit STEER90** 1 folha / 02.422101  
 1 hoja /  
 1 vantail /  
 1 leaf /

**Kit STEER90** 2 folhas / 02.422102  
 2 hojas /  
 2 vantaux /  
 2 leaves /

Abertura a 180° / Ouverture a 180°  
 Apertura a 180° / 180° opening

**Kit STEER180** 1 folha / 02.422121  
 1 hoja /  
 1 vantail /  
 1 leaf /

**Kit STEER180** 2 folhas / 02.422122  
 2 hojas /  
 2 vantaux /  
 2 leaves /



Motor / Motor / Moteur / Operator

**STEER90** abertura a 90°/110° / 02.251401  
 abertura a 90°/110° /  
 ouverture a 90°/110° /  
 90°/110° opening /

**STEER180** abertura a 180° / 02.251402  
 abertura a 180° /  
 ouverture a 180° /  
 180° opening /

Caixa de enterrar / Caja de enterrar  
 / Boîte pour enterrer / Sinking box

**Box 90°** zincada com desbloqueio / 02.251403  
 cincada con desbloqueo /  
 zinguée avec débrayage /  
 zinc plated with decluth /

**Box 90°** zincada c/ desbl. e fins de curso / 02.251405  
 cincada c/ desbl. y finales de carrera /  
 zinguée avec déb. et fins de course /  
 zinc plated w/ decl. and limit switches /

**Box 180°** zincada com desbloqueio / 02.251404  
 cincada con desbloqueo /  
 zinguée avec débrayage /  
 zinc plated with decluth /

Outros acessórios

/ Otros accesorios  
 / Autres accessoires  
 / Other accessories

**Fechadura eléctrica vertical** 12V / 02.276011  
 Cerradura eléctrica vertical /  
 Serrure électrique verticale /  
 Electrical vertical lock /

**Fotocélulas de parede** / 02.400023  
 Fotocélulas de pared /  
 Photocellules murales /  
 Surface mount photocells /

**Espira magnética 2 canais** / 02.270201  
 Bucle magnético 2 canales /  
 Détecteur à boucle 2 canaux /  
 Loop detector 2 channels /

**Emissor 'Black+Inox' 4 canais** / 02.400039  
 Mando 'Black+Inox' 4 canales /  
 Émetteur 'Black+Inox' 4 canaux /  
 Emitter 'Black+Inox' 4 channels /

**Selector de chave** / 02.270213  
 Selector de llave /  
 Sélecteur à clé /  
 Keyswitch /

**Selector digital sem fios** / 02.400018  
 Teclado digital inalámbrico /  
 Clavier numérique sans fil /  
 Wireless digital keypad /

**Receptor de longo alcance, 2 canais** / 02.400021  
 Receptor de largo alcance, 2 canales /  
 Récepteur longue portée, 2 canaux /  
 Long range receiver, 2 channels /



**F-330**

**F-350**

**F-390**

**M21230**

**STAC/STAWC**

**STÄ/STÄW**

MOTOR PARA PORTÕES SECCIONADOS

MOTOR DE PUERTAS SECCIONALES

MOTEUR POUR PORTES SECTIONNELLES

SECTIONAL DOORS OPERATOR

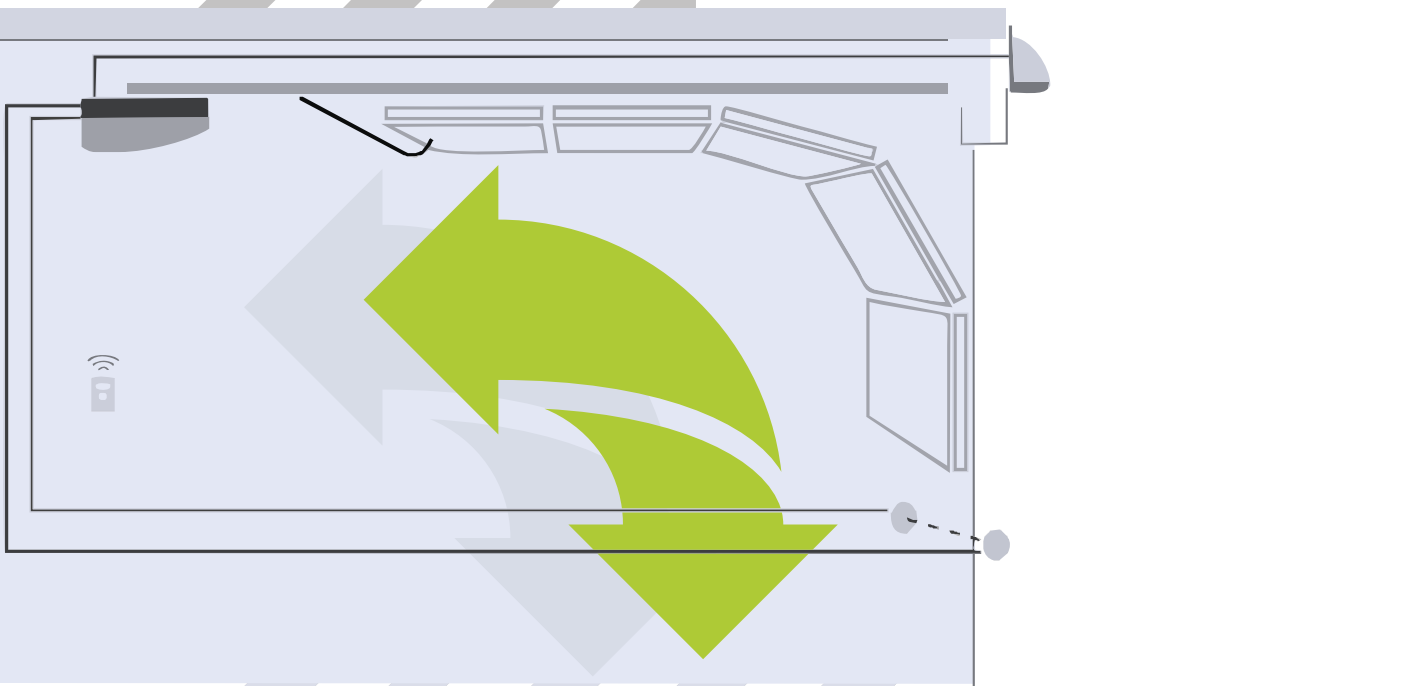

MOTOR DE ARRASTO  
MOTOR DE TECHO  
MOTEUR DE PLAFOND  
CEILING MOUNT OPENER

# F-330



CE

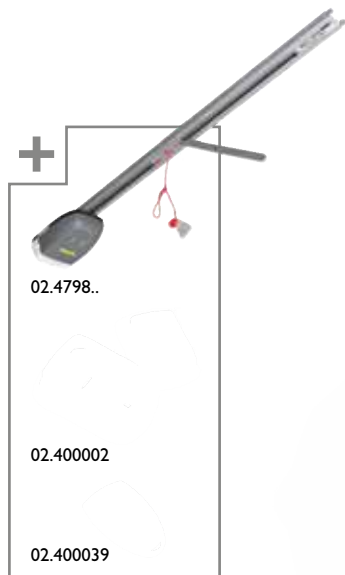

Alimentação / Alimentación / Alimentation / Power supply	V AC	230
Motor / Motor / Moteur / Motor	V DC	24
Potência / Potencia / Puissance / Power	W	90
Torque / Torque / Moment de force / Torque	N.m	600
Velocidade / Velocidad / Vitesse / Speed	cm/s	11.0
Área máx. da porta / Tamaño máx. de puerta / Taille max. de porte / Max. door size	m <sup>2</sup>	8
Fusível / Fusible / Fusible / Fuse	A (2x)	2,5
Modo económico / Stand-by / Mise en veille / Standby	W	4
Temperatura / Temperatura / Température / Temperature	°C	-20 ~ +50
Frequência / Frecuencia / Fréquence / Frequency	MHz	433 (50m)
Luz de cortesia / Luz de presencia / Éclairage de courtoisie / Courtesy light	(1x)	E14 25W
Placa de controlo / Central de mando / Logique de commande / Control card	integrada/integrada/intégrée/integrated	

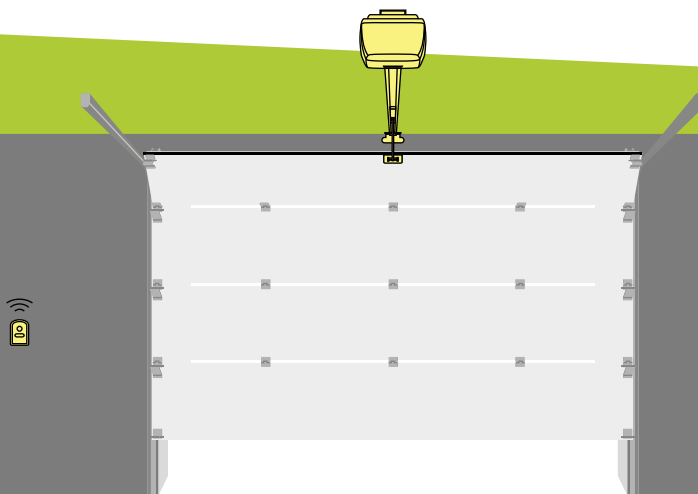

Motor de tecto para portões seccionados residenciais  
 / Motor de techo para puertas seccionales residenciales  
 / Moteur de plafond pour portes sectionnelles résidentielles  
 / Ceiling mount operator for residential sectional doors

Mainboard de nova geração controlada por sensores ópticos  
 / Carta madre de nueva generación con control por sensores ópticos  
 / Nouvelle génération de carte mère contrôlée par des capteurs optiques  
 / New generation mainboard controlled by optical sensors



Placa de potência independente com ajuste de força em tempo real  
 / Tarjeta de potencia independiente con ajuste de fuerza en tiempo real  
 / Carte de puissance avec réglage indépendant de la force en temps réel  
 / Power board with independent force adjustment in real time

Sensibilidade ultra-precisa com o encoder no interior da redutora  
 / Sensibilidad ultra precisa con el 'encoder' en el interior de la redutora  
 / Sensibilité ultra précise avec l'encodeur à l'intérieur du réducteur  
 / Ultra-precise sensitivity with the encoder inside the gearbox

Tracção por calha 'C' de aço galvanizado  
 / Tracción por guía 'C' de acero galvanizado  
 / Traction par rail 'C' en acier galvanisé  
 / Traction by galvanized steel 'C' rail

Pré-aviso de fecho e alarme de porta aberta  
 / Aviso previo de cierre y alarma de puerta abierta  
 / Pré alerte de fermeture et alarme de porte ouverte  
 / Pre-closure alert and open-door alarm

Codificação Rolling Code anti-cópia  
 / Codificación Rolling Code anticopia  
 / Codage Rolling Code anti-copie  
 / Anti-copy Rolling Code coding

Kit motor / Kit motor / Kit moteur / Operator's kit

Kit **F-330 - FK3000** 02.479030

Kit **F-330 - FK3300** 02.479033

Motor / Motor / Moteur / Operator

**F-330** 02.479900



Calha para motor / Guía para motor  
 / Rail pour moteur / Operator's track

(altura máx. da porta) / (altura máx. de la puerta)  
 / (hauteur max. de la porte) / (door's max. height)

<b>FK3000</b>	Calha de corrente Guía de cadena Rail à chaîne Chain track	até 2240mm hasta up to 2240mm	02.479830
---------------	---	-------------------------------------	-----------

<b>FK3300</b>	Calha de corrente Guía de cadena Rail à chaîne Chain track	até 2540mm hasta up to 2540mm	02.479833
---------------	---	-------------------------------------	-----------



Interruptor magnético sem fios  
 Interruptor magnético inalámbrico  
 Interrupteur magnétique sans fil  
 Wireless magnetic switch

Outros acessórios  
 / Otros accesorios  
 / Autres accessoires  
 / Other accessories

Emissor 'Black+Inox' 4 canais 02.400039  
 Mando 'Black+Inox' 4 canales  
 Émetteur 'Black+Inox' 4 canaux  
 Emitter 'Black+Inox' 4 channels

Botoneira de parede sem-fios 02.400002  
 Mando de pared inalámbrico  
 Bouton mural sans fil  
 Wireless push button station

Selector de chave 02.270213  
 Selector de llave  
 Sélecteur à clé  
 Keyswitch

Selector digital sem fios 02.400018  
 Teclado digital inalámbrico  
 Clavier numérique sans fil  
 Wireless digital keypad

Fotocélulas de parede 02.400023  
 Fotocélulas de pared  
 Photocellules murales  
 Wall mount photocells

Kit sistema fotoeléctrico 02.270300  
 Kit goma fotoeléctrica  
 Kit système photoélectrique  
 Photoelectric edges kit

Pirilampo 230V com antena 02.400010  
 Lámpara de destellos 230V con antena  
 Feu clignotant 230V avec antenne  
 Flashing light 230V with antenna

Kit interruptor magnético sem fios 02.400511  
 Kit interruptor magnético inalámbrico  
 Kit interrupteur magnétique sans fil  
 Kit wireless magnetic switch

Desembraiador externo com chave 02.400035  
 Desbloqueo exterior con llave  
 Débarayage externe à clé  
 External declutch with key

MOTOR DE ARRASTO  
MOTOR DETECHO  
MOTEUR DE PLAFOND  
CEILING MOUNT OPENER

# F-350

24v

15 m<sup>2</sup>

LED Display

Alarm



CE

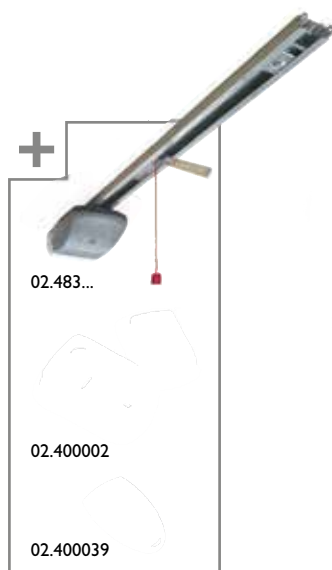

		F-350M	F-350G
Alimentação / Alimentación / Alimentation / Power supply	V AC	230	230
Motor / Motor / Moteur / Motor	V DC	24	24
Potência / Potencia / Puissance / Power	W	100	150
Intensidade / Absorción / Intensité / Absorption	A	0.43	0.65
Torque / Torque / Moment de force / Torque	N.m	700	1100
Velocidade / Velocidad / Vitesse / Speed	cm/s	11.0	11.0
Área máx. da porta / Tamaño máx. de puerta / Taille max. de porte / Max. door size	m <sup>2</sup>	10	15
Fusível / Fusible / Fusible / Fuse	A (2x)	2,5	2,5
Modo económico / Stand-by / Mise en veille / Standby	W	4	4
Temperatura / Temperatura / Température / Temperature	°C	-20 ~ +50	-20 ~ +50
Frequência / Frecuencia / Fréquence / Frequency	MHz	433 (50m)	433 (50m)
Luz de presença / Luz de cortesía / Éclairage de courtoisie / Courtesy light	(1x)	E14 25W	E14 25W
Placa de controlo / Central de mando / Logique de commande / Control card		integrada/integrada/intégrée/integrated	



Motor de tecto para portões seccionados ou basculantes, residenciais e de condomínio  
 / Motor de techo para puertas seccionales o basculantes, residenciales y de comunidad  
 / Moteur de plafond pour portes sectionnelles ou basculantes, residentielles et collectives  
 / Ceiling mount operator for residential and condominium sectional or up-and-over doors

Sensibilidade a pequenos obstáculos com inversão automática  
 / Sensibilidad a pequeños obstáculos con inversión automática  
 / Sensibilité aux petits obstacles avec inversion automatique  
 / Sensitivity to small obstacles with automatic reversal

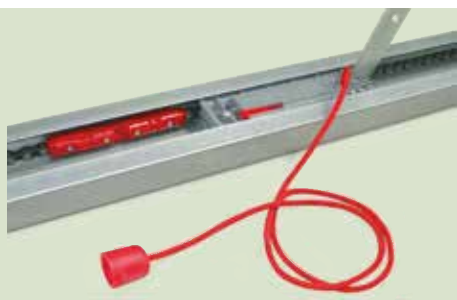

Programação muito simples com display luminoso  
 / Programación muy fácil con pantalla LED  
 / Programmation très facile avec écran LED  
 / User friendly programming with LED display

Tracção por calha 'C' de aço galvanizado  
 / Tracción por guía 'C' de acero galvanizado  
 / Traction par rail 'C' en acier galvanisé  
 / Traction by galvanized steel 'C' rail

Pré-aviso de fecho e alarme de porta aberta  
 / Aviso previo de cierre y alarma de puerta abierta  
 / Pré alerte de fermeture et alarme de porte ouverte  
 / Pre-closure alert and open-door alarm

Controlo electrónico de curso com abrandamento  
 / Controló electrónico de carrera y deceleración  
 / Contrôle de position par encodeur et ralentissement  
 / Tracking control by encoder and deceleration

Função alarme de manutenção (2000 ciclos)  
 / Función aviso de manutención (2000 ciclos)  
 / Fonction alerte d'entretien (2000 cycles)  
 / Maintenance alert (2000 cycles)

Codificação Rolling Code anti-cópia  
 / Codificación Rolling Code anticopia  
 / Codage Rolling Code anti-copie  
 / Anti-copy Rolling Code coding



Kit motor / Kit motor / Kit moteur / Operator's kit

Calha de corrente / Guia de cadena / Rail à chaîne / Chain track

Kit <b>F-350M - SK3000</b>	02.487300
Kit <b>F-350M - SK3300</b>	02.487330
Kit <b>F-350M - SK3600</b>	02.487360
Kit <b>F-350M - SK4300</b>	02.487430

Calha de correia / Guia de correa / Rail à courroie / Belt track

Kit <b>F-350G - SK3000B</b>	02.487308
Kit <b>F-350G - SK3300B</b>	02.487338
Kit <b>F-350G - SK3600B</b>	02.487368
Kit <b>F-350G - SK4300B</b>	02.487438

Kit <b>F-350G - SK3000</b>	02.410300
Kit <b>F-350G - SK3300</b>	02.410330
Kit <b>F-350G - SK3600</b>	02.410360
Kit <b>F-350G - SK4300</b>	02.410430

Kit <b>F-350G - SK3000B</b>	02.410308
Kit <b>F-350G - SK3300B</b>	02.410338
Kit <b>F-350G - SK3600B</b>	02.410368
Kit <b>F-350G - SK4300B</b>	02.410438



Calha para motor / Guia para motor / Rail pour moteur / Operator's track  
 (altura máx. da porta) / (altura máx. de la puerta) / (hauteur max. de la porte) / (door's max. height)



Calha de corrente / Guia de cadena / Rail à chaîne / Chain track

<b>SK3000</b> - 2200mm	02.483000
<b>SK3300</b> - 2500mm	02.483300
<b>SK3600</b> - 2800mm	02.483600
<b>SK4300</b> - 3500mm	02.484300

Calha de correia / Guia de correa / Rail à courroie / Belt track

<b>SK3000B</b> - 2200mm	02.483008
<b>SK3300B</b> - 2500mm	02.483308
<b>SK3600B</b> - 2800mm	02.483608
<b>SK4300B</b> - 3500mm	02.484308

Motor / Motor / Moteur / Operator

<b>F-350M</b>	02.487000
<b>F-350G</b>	02.481000

Accesórios: ver F-390 / Accessoires: voir F-390  
 Accessories: véase F390 / Accessories: see F-390

MOTOR DE ARRASTO  
MOTOR DE TECHO  
MOTEUR DE PLAFOND  
CEILING MOUNT OPENER

# F-390

24v

18m<sup>2</sup>

LED  
Display

Alarm



CE



**SKY Master**  
Professional

Alimentação / Alimentación / Alimentation / Power supply	V AC	230
Motor / Motor / Moteur / Motor	V DC	24
Potência / Potencia / Puissance / Power	W	200
Torque / Torque / Moment de force / Torque	N.m	1200
Velocidade / Velocidad / Vitesse / Speed	cm/s	11.0
Área máx. da porta / Tamaño máx. de puerta / Taille max. de porte / Max. door size	m <sup>2</sup>	18
Fusível / Fusible / Fusible / Fuse	A (2x)	2,5
Modo económico / Stand-by / Mise en veille / Standby	W	8
Temperatura / Temperatura / Température / Temperature	°C	-20 ~ +50
Frequência / Frecuencia / Fréquence / Frequency	MHz	433 (50m)
Luz de cortesia / Luz de presencia / Éclairage de courtoisie / Courtesy light	(1x)	E14 25W

Placa de controlo / Central de mando / Logique de commande / Control card

integrada/integrada/intégrée/integrated

**HEAVY  
DUTY**

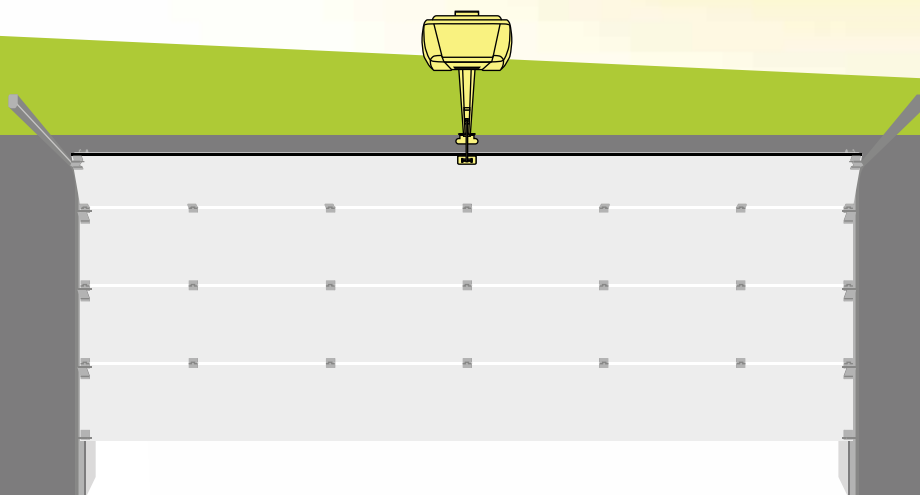

Motor de tecto para portões seccionados ou basculantes de grandes dimensões  
 / Motor de techo para puertas seccionales o basculantes de grandes dimensiones  
 / Moteur de plafond pour portes sectionnelles ou basculantes de grandes tailles  
 / Ceiling mount operator for big size sectional or up-and-over doors

Sensibilidade a pequenos obstáculos com inversão automática  
 / Sensibilidad a pequeños obstáculos con inversión automática  
 / Sensibilité aux petits obstacles avec inversion automatique  
 / Sensitivity to small obstacles with automatic reversal



Programação muito simples com display luminoso  
 / Programación muy fácil con pantalla LED  
 / Programmation très facile avec écran LED  
 / User friendly programming with LED display

Tracção por calha 'C' reforçada  
 / Tracción por guía 'C' reforzada  
 / Traction par rail 'C' renforcé  
 / Traction by reinforced 'C' rail

Pré-aviso de fecho e alarme de porta aberta  
 / Aviso previo de cierre y alarma de puerta abierta  
 / Pré alerte de fermeture et alarme de porte ouverte  
 / Pre-closure alert and open-door alarm

Controlo electrónico de curso com abrandamento  
 / Controló electrónico de carrera y deceleración  
 / Contrôle de position par encodeur et ralentissement  
 / Tracking control by encoder and deceleration

Função alarme de manutenção (2000 ciclos)  
 / Función aviso de manutención (2000 ciclos)  
 / Fonction alerte d'entretien (2000 cycles)  
 / Maintenance alert (2000 cycles)

Codificação Rolling Code anti-cópia  
 / Codificación Rolling Code anticopia  
 / Codage Rolling Code anti-copie  
 / Anti-copy Rolling Code coding

Kit motor / Kit motor / Kit moteur / Operator's kit

Kit **F-390 - LK4300** 02.412430

Kit **F-390 - LK5000** 02.412500

Motor / Motor / Moteur / Operator

**F-390** 02.412000



Calha para motor / Guia para motor  
 / Rail pour moteur / Operator's track

(altura máx. da porta) / (altura máx. de la puerta)  
 / (hauteur max. de la porte) / (door's max. high)

<b>LK4300</b>	Calha de corrente Guia de cadena Rail à chaîne Chain track	até 3500mm hasta up to	até 3500mm hasta up to	02.484301
<b>LK5000</b>	Calha de corrente Guia de cadena Rail à chaîne Chain track	até 4300mm hasta up to	até 4300mm hasta up to	02.485001



Interruptor magnético sem fios  
 Interruptor magnético inalámbrico  
 Interrupteur magnétique sans fil  
 Wireless magnetic switch

Outros acessórios  
 / Otros accesorios  
 / Autres accessoires  
 / Other accessories

Emissor 'Black+Inox' 4 canais 02.400039  
 Mando 'Black+Inox' 4 canales  
 Émetteur 'Black+Inox' 4 canaux  
 Emitter 'Black+Inox' 4 channels

Botoneira de parede sem-fios 02.400002  
 Mando de pared inalámbrico  
 Bouton mural sans fil  
 Wireless push button station

Selector de chave 02.270213  
 Selector de llave  
 Sélecteur à clé  
 Keyswitch

Selector digital sem fios 02.400018  
 Teclado digital inalámbrico  
 Clavier numérique sans fil  
 Wireless digital keypad

Fotocélulas de parede 02.400023  
 Focélulas de pared  
 Photocélules murales  
 Wall mount photocells

Kit sistema fotoeléctrico 02.270300  
 Kit goma fotoeléctrica  
 Kit système photoélectrique  
 Photoelectric edges kit

Pirilampo 230V com antena 02.400010  
 Lámpara de destellos 230V con antena  
 Feu clignotant 230V avec antenne  
 Flashing light 230V with antenna

Kit interruptor magnético sem fios 02.400511  
 Kit interruptor magnético inalámbrico  
 Kit interrupteur magnétique sans fil  
 Kit wireless magnetic switch

Desembraiaador externo com chave 02.400035  
 Desbloqueo exterior con llave  
 Débarayage externe à clé  
 External declutch with key

MOTOR DE ARRASTO  
 MOTOR DETECHO  
 MOTEUR DE PLAFOND  
 CEILING MOUNT OPENER

# M21230



CE



Tensão / Voltaje / Tension / Voltage	V AC	230
Potência / Potencia / Puissance / Power	W	380
Intensidade / Absorción / Intensité / Absorption	A	3.5
Torque / Torque / Moment de force / Torque	N.m	800
Velocidade / Velocidad / Vitesse / Speed	cm/s	13.0
Área máx. da porta / Tamaño máx. de puerta / Taille max. de porte / Max. door size	m <sup>2</sup>	21
Protecção térmica / Protección térmica / Protection thermique / Thermal protection	°C	80
Temperatura / Temperatura / Température / Temperature	°C	-20 ~ +50
Luz de presença / Luz de cortesia / Éclairage de courtoisie / Courtesy light	(1x)	E27 60W
Frequência / Frecuencia / Fréquence / Frequency	SkyMaster External Receiver: MHz	433 (50m)

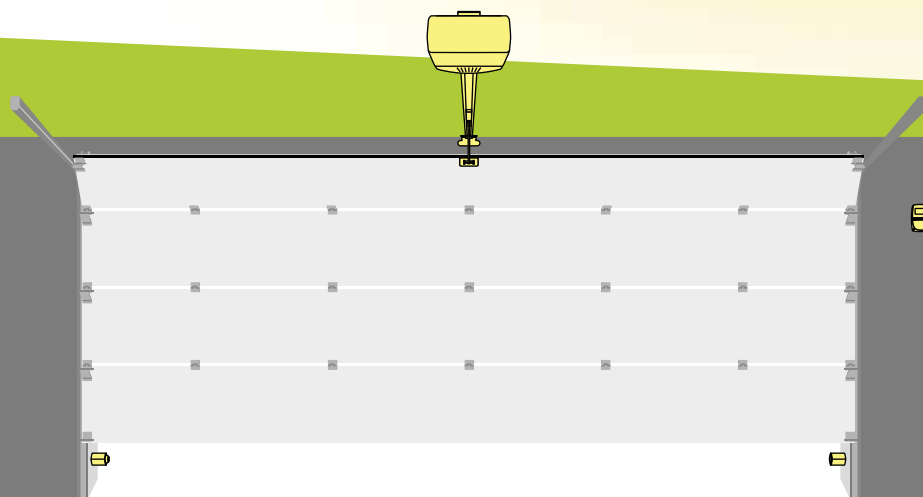

Motor de tecto para portões seccionados de grandes dimensões semi-industriais  
 / Motor de techo para puertas seccionales de grandes dimensiones semi-industriales  
 / Moteur de plafond pour portes sectionnelles de grandes tailles semi-industrielles  
 / Ceiling mount operator for big size semi-industrial sectional doors

Sensibilidade a pequenos obstáculos com inversão automática  
 / Sensibilidad a pequeños obstáculos con inversión automática  
 / Sensibilité aux petits obstacles avec inversion automatique  
 / Sensitivity to small obstacles with automatic reversal

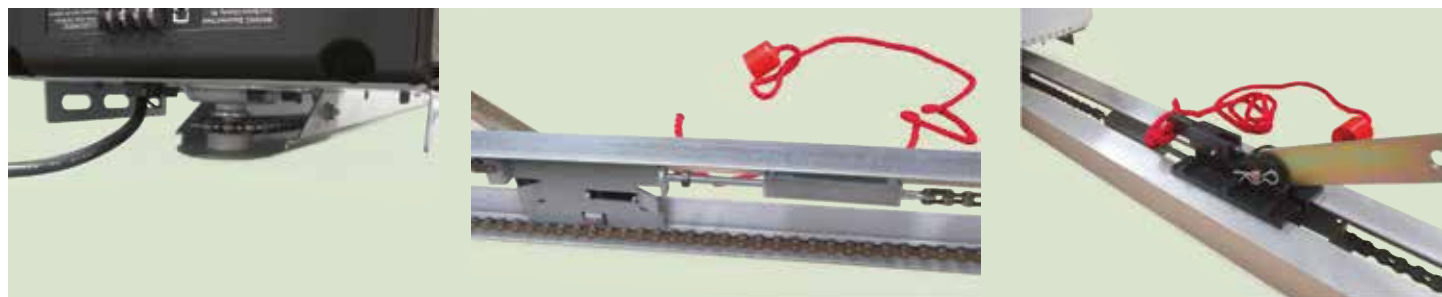

**Fins de curso mecânicos**  
 / Finales de carrera mecánicas  
 / Fins de course mécaniques  
 / Mechanical limit switches

**Calha reforçada duplo 'L'**  
 / Guía reforzada 'L' doble  
 / Rail double 'L', renforcé  
 / Reinforced double 'L' rail

**Sistema de tracção completo em aço galvanizado**  
 / Sistema de tracción completo en acero galvanizado  
 / Système de traction complète en acier galvanisé  
 / Traction system entirely made of galvanized steel

**Controlo independente da força de subida e descida com abrandamento**  
 / Control independiente de la fuerza de elevación y descenso y deceleración  
 / Contrôle indépendant de la force de montée et descente et ralentissement  
 / Independent programming of up and down force and deceleration

**Função fecho automático**  
 / Función auto-cierre  
 / Fonction fermeture automatique  
 / Auto-close function

**Codificação Rolling Code anti-cópia**  
 / Codificación Rolling Code anticopia  
 / Codage Rolling Code anti-copie  
 / Anti-copy Rolling Code coding

Kit motor / Kit motor / Kit moteur / Operator's kit  
 (altura máx. da porta) / (altura máx. de la puerta) / (hauteur max. de la porte) / (door's max. height)



<b>Kit M21230 Base - 2500</b>	02.462250
<b>Kit M21230 Base - 3000</b>	02.462300
<b>Kit M21230 Base - 3500</b>	02.462350
<b>Kit M21230 Base - 4500</b>	02.462450
<b>Kit M21230 Radio - 2500</b>	02.461250
<b>Kit M21230 Radio - 3000</b>	02.461300
<b>Kit M21230 Radio - 3500</b>	02.461350
<b>Kit M21230 Radio - 4500</b>	02.461450

**Calha para motor / Guía para motor**  
 / Rail pour moteur / Operator's track

(altura máx. da porta) / (altura máx. de la puerta)  
 / (hauteur max. de la porte) / (door's max. height)

<b>Calha de corrente</b> Guía de cadena Rail à chaîne Chain track	<b>2500mm</b>	<b>02.462925</b>
<b>Calha de corrente</b> Guía de cadena Rail à chaîne Chain track	<b>3000mm</b>	<b>02.462930</b>
<b>Calha de corrente</b> Guía de cadena Rail à chaîne Chain track	<b>3500mm</b>	<b>02.462935</b>
<b>Calha de corrente</b> Guía de cadena Rail à chaîne Chain track	<b>4500mm</b>	<b>02.462945</b>

**Motor / Motor / Moteur / Operator**

+ botoneira e fotocélulas + bouton mural et photocellules  
 + mando de pared y fotocélulas + push button and photocells

**M21230** 02.462900



**Sistema vedante fotoeléctrico**  
 Sistema goma fotoeléctrica  
 Système borde photoélectrique  
 Photoelectric edge system

02.270300



**Peças de substituição do motor**  
 / Recambios del motor  
 / Pièces de rechange du moteur  
 / Operator's spare parts

<b>Emissor 'Black+Inox' 4 canais</b> Mando 'Black+Inox' 4 canales Émetteur 'Black+Inox' 4 canaux Emitter 'Black+Inox' 4 channels	<b>02.400029</b>
<b>Botoneira de parede sem-fios</b> Mando de pared inalámbrico Bouton mural sans fil Wireless push button station	<b>02.400002</b>
<b>Fotocélulas de parede M21230</b> Fotocélulas de pared M21230 Photocellules murales M21230 Surface mount M21230 photocells	<b>02.462901</b>
<b>Kit sistema fotoeléctrico</b> Kit goma fotoeléctrica Kit système photoélectrique photoelectric edges kit	<b>02.270300</b>
<b>Desembraiador externo com chave</b> Desbloqueo exterior con llave Débrayage externe à clé External declutch with key	<b>02.400015</b>
<b>Chave extra para 02.400015</b> Llave extra para 02.400015 Clé extra pour 02.400015 Extra key for 02.400015	<b>02.400016</b>
<b>Kit interruptor magnético sem fios</b> Kit interruptor magnético inalámbrico Kit interrupteur magnétique sans fil Kit wireless magnetic switch	<b>02.400511</b>

MOTOR AO VEIO  
 MOTORREDUCTOR AL EJE  
 MOTEUR À PRISE DIRECTE  
 GEAR MOTOR

# STAC/STAWC



CE



02.401940



**STAWC E      STAWC KE      STAC E      STAC KE**

Tensão / Voltaje / Tension / Voltage	V AC	230	230	400	400
Potência / Potencia / Puissance / Power	W	300	300	370	370
Intensidade / Absorción / Intensité / Absorption	A	3.8	3.8	2.1	2.1
Torque / Torque / Moment de force / Torque	N.m	50	50	80	80
Acoplamento / Boca de eje / Emboiture d'arbre / Shaft sleeve	mm / "	25,4/1	25,4/1	25,4/1	25,4/1
Velocidade / Velocidad / Vitesse / Speed	rpm	24	24	24	24
Sistema secundário / Sistema secundario / Système secondaire / Secondary system		Cadernal / Elevador de cadena / Treuil à chaîne / Chain hoist	Desbloqueo / Desbloqueo / Débrayage / Declutching	Cadernal / Elevador de cadena / Treuil à chaîne / Chain hoist	Desbloqueo / Desbloqueo / Débrayage / Declutching
Ciclo de trabalho / Ciclo de trabajo / Rapport cyclique / Duty cycle	%	25	25	40	40
Índice de protecção / Índice de protección / Indice de protection / IP Code	(IEC 60529)	IP 65	IP 65	IP 65	IP 65
Temperatura / Temperatura / Température / Temperature	°C	-10 ~ +60	-10 ~ +60	-10 ~ +60	-10 ~ +60
Placa de controlo / Central de mando / Logique de commande / Control card		ECO integrada/integrada/intégrée/integrated			

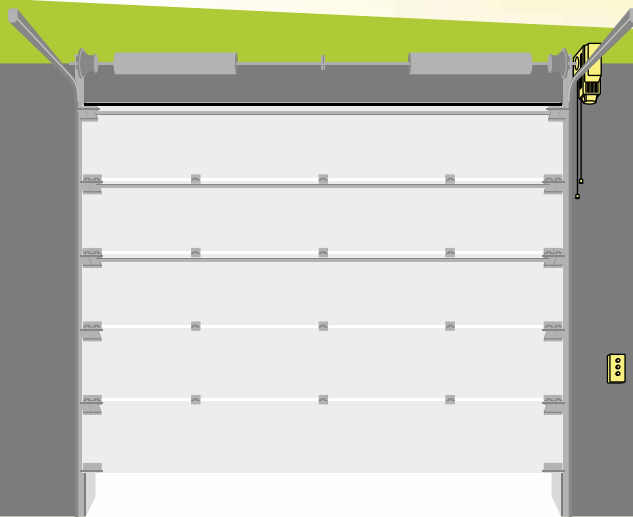

Motorreductor para portões seccionados industriais  
 / Motorreductor para puertas seccionales industriales  
 / Moto réducteur pour portes sectionnelles industrielles  
 / Gear motor for industrial sectional doors

Corpo em alumínio injectado  
 / Cuerpo de aluminio injectado  
 / Corps en aluminium injecté  
 / Pressure cast aluminium housing

Quadro ECO integrado para uso em 'homem-presente'  
 / Cuadro ECO integrado para uso 'hombre presente'  
 / Cadre ECO intégré pour usage 'homme mort'  
 / Integrated ECO card for 'dead man' use



Maior segurança com fins de curso mecânicos duplos  
 / Mayor seguridad con finales de carrera dobles  
 / Plus de sécurité avec fins de courses mécaniques doubles  
 / Greater security with double mechanical limit switches



Para eixos de molas de 1" com escatel 3/8"  
 / Para ejes de muelles de 1" con clavetero 3/8"  
 / Pour arbres de ressorts de 1" avec clavette 3/8"  
 / For 1" spring shafts with 3/8" keyway

Redutora em bronze de elevada qualidade  
 / Transmisión de bronce de alta calidad  
 / Démultiplicateur en bronze de haute qualité  
 / Worm drive of high quality bronze

Lubrificação permanente e protecção térmica  
 / Lubricación permanente y protección térmica  
 / Lubrification permanente et protection thermique  
 / Lifetime lubrication and thermal protection

Muito silencioso e grande poupança de espaço  
 / Muy silencioso y gran ahorro de espacio  
 / Très silencieux et grande économie d'espace  
 / Very quiet and great space saving

Kit motor / Kit motor / Kit moteur / Operator's kit



Kit <b>STAWC E</b>	02.401421
Kit <b>STAWC KE</b>	02.401420
Kit <b>STAC E</b>	02.401621
Kit <b>STAC KE</b>	02.401620

Motor / Motor / Moteur / Operator

+ quadro integrado + cadre intégré  
 + cuadro integrado + integrated board

<b>STAWC E</b>	02.401821
<b>STAWC KE</b>	02.401820
<b>STAC E</b>	02.401721
<b>STAC KE</b>	02.401720

Outros acessórios

/ Otros accesorios  
 / Autres accessoires  
 / Other accessories

<b>Corrente extra</b> Cadena extra Chaîne extra Extra chain	02.401980
<b>Elo de ligação para 02.401980</b> Anillo de acoplamiento para 02.401980 Maillon de jonction pour 02.401980 Chain connector for 02.401980	02.401989
<b>Selector de chave</b> Selector de llave Sélécteur à clé Keyswitch	02.270213
<b>Botoneira com cabo 9m e ficha</b> Mando de pared con cable 9m y clavija Bouton mural avec cable 9m et fiche Push button station with 9m cable and plug	02.401940
<b>Kit interruptor magnético sem fios</b> Kit interruptor magnético inalámbrico Kit interrupteur magnétique sans fil Kit wireless magnetic switch	02.400511
<b>Travão excêntrico de segurança 1"</b> Freno excéntrico de seguridad 1" Frein excentrique de sécurité 1" Emergency excentric brake 1"	02.400490

**ECO**

Funções / Funciones / Fonctions / Functions

Homem-presente / Hombre-presente / Homme mort / Dead man

Abertura por impulso / Apertura por impulso / Ouverture par pulsion / Impulse Open

V AC 3~ - 1~	400 - 230
V DC	24
KW - A	1.1 - 4
mA	250
(IEC 60529)	IP 44
°C	-5 ~ +55

MOTOR AO VEIO  
MOTORREDUCTOR AL EJE  
MOTEUR À PRISE DIRECTE  
GEAR MOTOR

# STÄ/STAW

230v  
400v

Alu  
Resistance

Safety  
BREAK

slim

CE

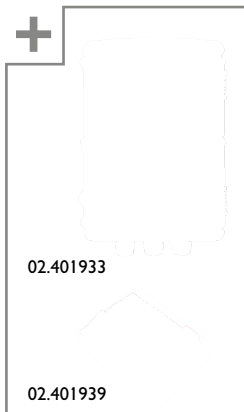

**SKY Master**  
Professional



STAW E

STAW KE

STA E

STA KE

Tensão / Voltaje / Tension / Voltage	V AC	230	230	400	400
Potência / Potencia / Puissance / Power	W	300	300	370	370
Intensidade / Absorción / Intensité / Absorption	A	3.8	3.8	2.1	2.1
Torque / Torque / Moment de force / Torque	N.m	50	50	80	80
Acoplamento / Árbol hueco / Emboiture d'arbre / Shaft sleeve	mm / "	25,4/1	25,4/1	25,4/1	25,4/1
Velocidade / Velocidad / Vitesse / Speed	rpm	24	24	24	24
Ciclo de trabalho / Ciclo de trabajo / Rapport cyclique / Duty cycle	%	25	25	40	40
Índice de protecção / Índice de protección / Indice de protection / IP Code	(IEC 60529)	IP 65	IP 65	IP 65	IP 65
Temperatura / Temperatura / Température / Temperature	°C	-10 ~ +60	-10 ~ +60	-10 ~ +60	-10 ~ +60
Sistema secundário / Sistema secundario / Système secondaire / Secondary system		Cadernal / Elevador de cadena / Treuil a chaîne / Chain hoist	Desbloqueo / Desbloqueo / Débrayage / Declutching	Cadernal / Elevador de cadena / Treuil a chaîne / Chain hoist	Desbloqueo / Desbloqueo / Débrayage / Declutching

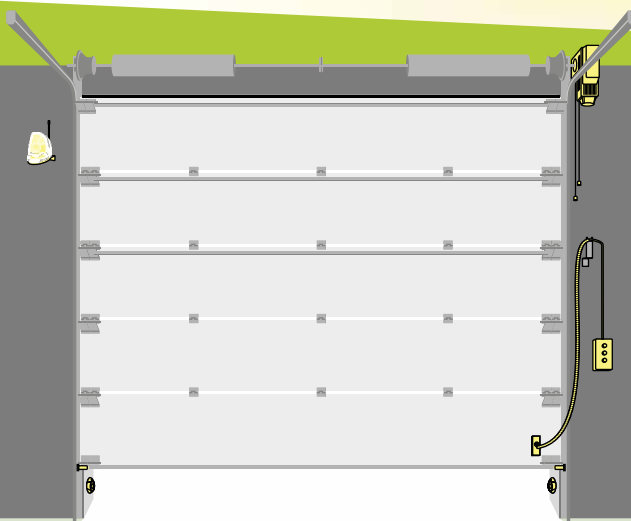

Motorreductor para portões seccionados industriais  
 / Motorreductor para puertas seccionales industriales  
 / Moto réducteur pour portes sectionnelles industrielles  
 / Gear motor for industrial sectional doors

Redutora em bronze de elevada qualidade  
 / Transmisión de bronce de alta calidad  
 / Démultiplicateur en bronze de haute qualité  
 / Worm drive of high quality bronze

Quadro MAXI multifunções  
 / Cuadro MAXI multifunciones  
 / Cadre MAXI multifonctions  
 / Multifunctional MAXI card



Muito silencioso e grande poupança de espaço  
 / Muy silencioso y gran ahorro de espacio  
 / Très silencieux et grande économie d'espace  
 / Very quiet and great space saving



Para eixos de molas de 1" com escatel 3/8"  
 / Para ejes de muelles de 1" con chavetero 3/8"  
 / Pour arbres de ressorts de 1" avec clavette 3/8"  
 / For 1" spring shafts with 3/8" keyway

Maior segurança com fins de curso mecânicos duplos  
 / Mayor seguridad con finales de carrera dobles  
 / Plus de sécurité avec fins de courses mécaniques doubles  
 / Greater security with double mechanical limit switches

Corpo em alumínio injectado  
 / Cuerpo de aluminio inyectado  
 / Corps en aluminium injecté  
 / Pressure cast aluminium housing

Lubrificação permanente e protecção térmica  
 / Lubricación permanente y protección térmica  
 / Lubrification permanente et protection thermique  
 / Lifetime lubrication and thermal protection

Kit motor / Kit motor / Kit moteur / Operator's kit



Kit <b>STAW E</b>	02.401433
Kit <b>STAW KE</b>	02.401432
Kit <b>STA E</b>	02.401543
Kit <b>STA KE</b>	02.401533

**Outros acessórios**

/ Otros accesorios  
 / Autres accessoires  
 / Other accessories

**Corrente extra** 02.401980  
 Cadena extra  
 Chaîne extra  
 Extra chain

**Elo de ligação para 02.401980** 02.401989  
 Anillo de acoplamiento para 02.401980  
 Maillon de jonction pour 02.401980  
 Chain connector for 02.401980

**Emissor 'Black+Inox' 4 canais** 02.400039  
 Mando 'Black+Inox' 4 canales  
 Émetteur 'Black+Inox' 4 canaux  
 Emitter 'Black+Inox' 4 channels

**Selector digital sem fios** 02.400018  
 Teclado digital inalámbrico  
 Clavier numérique sans fil  
 Wireless digital keypad

**Receptor externo 4 canais** 02.400013  
 Receptor externo 4 canales  
 Récepteur externe 4 canaux  
 External receiver 4 channels

**Fotocélulas de parede** 02.400023  
 Fococélulas de pared  
 Photocellules murales  
 Surface mount photocells

**Kit sistema fotoeléctrico** 02.401959  
 Kit goma fotoeléctrica  
 Kit système photoélectrique  
 Photoelectric edges kit

**Pirilampo 230V com antena** 02.400010  
 Lámpara de destellos 230V con antena  
 Feu clignotant 230V avec antenne  
 Flashing light 230V with antenna

**Kit interruptor magnético sem fios** 02.400511  
 Kit interruptor magnético inalámbrico  
 Kit interrupteur magnétique sans fil  
 Kit wireless magnetic switch

**Travão excêntrico de segurança 1"** 02.400490  
 Freno excéntrico de seguridad 1"  
 Frein excentrique de sécurité 1"  
 Emergency excentric brake 1"

**MAXI**

Funções / Funciones / Fonctions / Functions

Homem-presente / Hombre-presente / Homme mort / Dead man

Abertura-Fecho por impulso / Apertura-Cierre por impulso / Ouverture-Fermeture par pulsion / Impulse Open-Close

Placa ZM / Carta ZM / Logique ZM / ZM Card

Fecho automático / Auto-cierre / Fermeture automatique / Auto-close

Operação remota / Operación remota / Operation à distance / Remote operation

Fotocélulas e Pirlampo / Fococelulas y Destellos / Photocellules et Clignotant / Photocells and Flashing light

Sistema fotoeléctrico / Goma photoeléctrica / Barre palpeuse photoélectrique / Photoeyed edge

V AC 3~ - 1~	400 - 230
V DC	24
KW - A	2.2 - 6
mA	250
(IEC 60529)	IP 44
°C	-10 ~ +60

Motor / Motor / Moteur / Operator

<b>STAW E</b>	02.401811
<b>STAW KE</b>	02.401810
<b>STA E</b>	02.401711
<b>STA KE</b>	02.401710



ZM card



02.401959

Sistema vedante fotoeléctrico  
 Sistema goma fotoeléctrica  
 Système de bord photoélectrique  
 Photoelectric edge system



# SMM/SMM-E ROTOR SMM-100|230 QL-600

MOTOR PARA ESTORES E GRADES DE ENROLAR  
MOTOR PARA PERSIANAS Y PUERTAS ENROLLABLES  
MOTEUR POUR STORES ET PORTES ENROULABLES  
ROLLING SHUTTERS OPERATOR

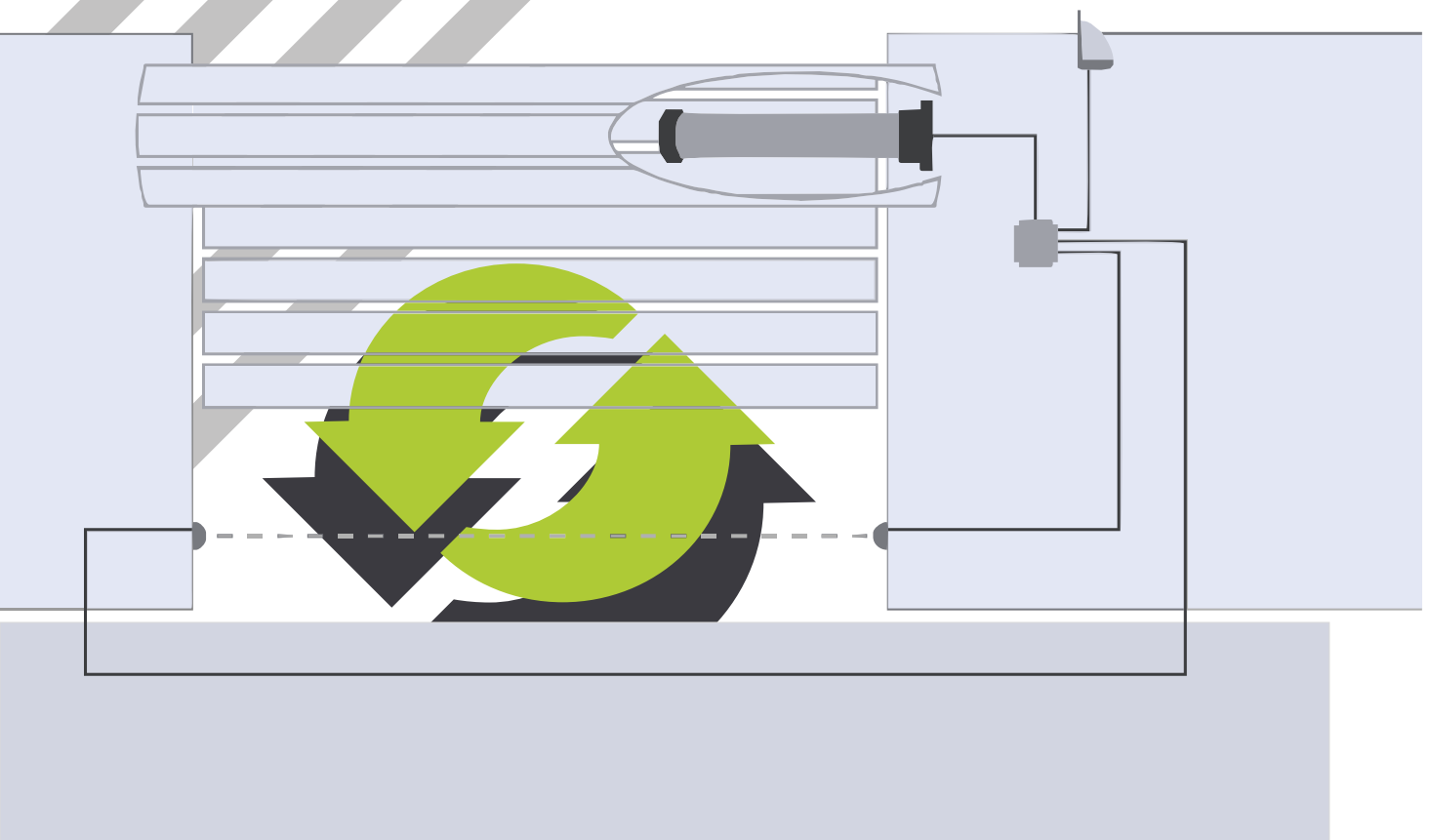

MOTOR TUBULAR PARA ESTORES/GRADES  
 MOTOR TUBULAR PARA PERSIANAS/PUERTAS ENROLLABLES  
 MOTEUR TUBULAIRE POUR STORES/PORTES ENROULABLES  
 TUBULAR MOTOR FOR BLINDS/ROLLING SHUTTERS

# SMM/SMM-E



CE



**SMM-E 50/10    SMM-E 50/20    SMM-E 50/30**

Tensão / Voltaje / Tension / Voltage	VAC	230	230	230
Potência / Potencia / Puissance / Power	W	160	220	330
Intensidade / Absorción / Intensité / Absorption	A	0.72	0.95	1.3
Torque / Torque / Moment de force / Torque	N.m	10	20	30
Velocidade / Velocidad / Vitesse / Speed	rpm	17	17	17
Tempo de trabalho / Tiempo de trabajo / Temps de travail / Working cycle	min.	4	4	4
Protecção térmica / Protección térmica / Protection thermique / Thermal protection	°C	150	150	150
Índice de protecção / Índice de protección / Indice de protection / IP Code	(IEC 60529)	IP 44	IP 44	IP 44
Placa de controlo / Central de mando / Logique de commande / Control card	Integrada com receptor/Integrada con receptor/Intégrée avec récepteur/Integrated with receiver			
Frequência / Frecuencia / Fréquence / Frequency	MHz	433	433	433

**SMM 50/15    SMM 50/35**

Tensão / Voltaje / Tension / Voltage	VAC	230	230
Potência / Potencia / Puissance / Power	W	160	245
Intensidade / Absorción / Intensité / Absorption	A	0.74	1.02
Torque / Torque / Moment de force / Torque	N.m	15	35
Velocidade / Velocidad / Vitesse / Speed	rpm	13	13
Tempo de trabalho / Tiempo de trabajo / Temps de travail / Working cycle	min.	4	4
Protecção térmica / Protección térmica / Protection thermique / Thermal protection	°C	150	150
Índice de protecção / Índice de protección / Indice de protection / IP Code	(IEC 60529)	IP 44	IP 44

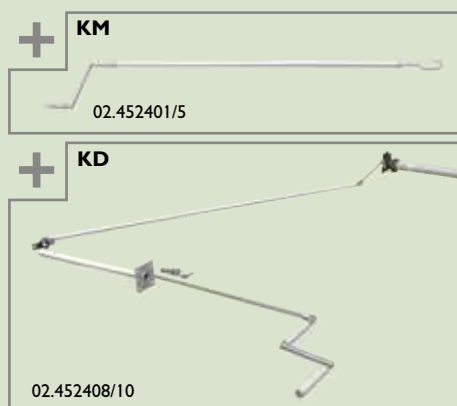

**SMM 50/50    SMM 60/80    SMM 60/100**

Diâmetro da coroa / Diámetro de la corona / Diamètre de la couronne / Crown diameter	mm	60	70	70
Tensão / Voltaje / Tension / Voltage	VAC	230	230	230
Potência / Potencia / Puissance / Power	W	270	360	430
Intensidade / Absorción / Intensité / Absorption	A	1.15	1.99	2.05
Torque / Torque / Moment de force / Torque	N.m	50	80	100
Velocidade / Velocidad / Vitesse / Speed	rpm	13	12	12
Tempo de trabalho / Tiempo de trabajo / Temps de travail / Working cycle	min.	4	4	4
Protecção térmica / Protección térmica / Protection thermique / Thermal protection	°C	150	130	130
Índice de protecção / Índice de protección / Indice de protection / IP Code	(IEC 60529)	IP 44	IP 44	IP 44

Corpo tubular com acabamento epoxi  
 / Cuerpo tubular con acabado epoxi  
 / Corps tubulaire avec peinture époxy  
 / Tubular body with epoxy finish

Para uso em veio octogonal de 60/70mm  
 / Para uso con eje octogonal de 60/70mm  
 / Pour utiliser avec arbre octogonal de 60/70mm  
 / Ready for 60/70mm octagonal shaft

Coroas em nylon/alumínio de elevada resistência  
 / Coronas de nylon/aluminio de alta resistencia  
 / Couronnes en nylon/aluminium d'haute résistance  
 / High strength nylon/aluminium crown



**Abertura manual de emergência, interior ou exterior na série SMM**  
 / Apertura manual de emergencia, interior o exterior en la serie SMM  
 / Ouverture manuelle d'urgence, pour l'intérieur ou extérieur en série SMM  
 / Manual emergency opening from the inside or outside on SMM series

**Lubrificação permanente**  
 / Lubricación permanente  
 / Lubrification permanente  
 / Permanent lubrication

**Fins de curso mecânicos**  
 / Finales de carrera mecánicas  
 / Fins de courses mécaniques  
 / Mechanical limit switches

**Permite o uso de fotocélulas ou sistema fotoelétrico**  
 / Permite el uso de células fotoeléctricas o goma sensible  
 / Permet l'utilisation de photocellules ou bords sensibles  
 / Ready for photocells or photoeye edges

**Receptor rádio incorporado na série E**  
 / Receptor de radio incorporado en la serie E  
 / Récepteur radio intégré, en série E  
 / E-series with built-in radio receiver

**Codificação Rolling Code anti-cópia**  
 / Codificación Rolling Code anticopia  
 / Codage Rolling Code anti-copie  
 / Anti-copy Rolling Code coding

**Motor / Motor / Moteur / Operator**

Veio octogonal Ø60      Arbre octogonal Ø60  
 Eje octogonal Ø60      Octogonal axle of Ø60

<b>SMM-E 50/10</b>	02.451110
<b>SMM-E 50/20</b>	02.451120
<b>SMM-E 50/30</b>	02.451130
<b>SMM 50/15</b>	02.451115
<b>SMM 50/35</b>	02.451135

**Quadros de controlo / Cuadros de maniobras  
 / Cadres de commande / Control boards**

<b>SKTB</b>	<b>com receptor e botões</b> con receptor y botones avec récepteur et boutons with receptor and push buttons	<b>02.400208</b>
<b>CTR30</b>	<b>com receptor</b> con receptor avec récepteur with receptor	<b>02.270130</b>
<b>CTR18</b>	<b>sem receptor</b> sin receptor sans récepteur without receptor	<b>02.270118</b>

**Outros acessórios**

/ Otros accesorios  
 / Autres accessoires  
 / Other accessories

<b>Botoneira de parede</b> Mando de pared Bouton mural Push button station	<b>02.320120</b>
<b>Emissor 'Black+Inox' 4 canais</b> Mando 'Black+Inox' 4 canales Émetteur 'Black+Inox' 4 canaux Emitter 'Black+Inox' 4 channels	<b>02.400039</b>
<b>Botoneira de parede sem-fios</b> Mando de pared inalámbrico Bouton mural sans fil Wireless push button station	<b>02.400002</b>
<b>Fotocélulas de parede</b> Fotocélulas de pared Photocellules murales Surface mount photocells	<b>02.400003</b>
<b>Kit manivela 1800mm 50/50</b> Kit manubrio 1800mm 50/50 Kit manivelle 1800mm 50/50 Hand crank kit 1800mm 50/50	<b>02.452401</b>
<b>Kit manivela 1800mm 60/80 - 60/100</b> Kit manubrio 1800mm 60/80 - 60/100 Kit manivelle 1800mm 60/80 - 60/100 Hand crank kit 1800mm 60/80 - 60/100	<b>02.452405</b>
<b>Kit desbloqueio exterior 50/50</b> Kit desbloqueo exterior 50/50 Kit déblocage extérieur 50/50 External manual opening kit 50/50	<b>02.452408</b>
<b>Kit desbloqueio exterior 60/80 - 60/100</b> Kit desbloqueo exterior 60/80 - 60/100 Kit déblocage extérieur 60/80 - 60/100 External manual opening kit 60/80 - 60/100	<b>02.452410</b>

**Kit motor / Kit motor  
 / Kit moteur / Operator's kit**

<b>SMM 50/50 KM</b>	02.452051
<b>SMM 50/50 KD</b>	02.452052
<b>SMM 60/80 KM</b>	02.452081
<b>SMM 60/80 KD</b>	02.452082
<b>SMM 60/100 KM</b>	02.452011
<b>SMM 60/100 KD</b>	02.452012

**Quadros de controlo / Cuadros de maniobras  
 / Cadres de commande / Control boards**

<b>CTR30</b>	<b>com receptor</b> con receptor avec récepteur with receptor	<b>02.270130</b>
<b>SKTB</b>	<b>com receptor e botões</b> con receptor y botones avec récepteur et boutons with receptor and push buttons	<b>02.400208</b>
<b>CTR18</b>	<b>sem receptor</b> sin receptor sans récepteur without receptor	<b>02.270118</b>



**Motor / Motor / Moteur / Operator**

<b>SMM 50/50</b>	02.452150
<b>SMM 60/80</b>	02.452180
<b>SMM 60/100</b>	02.452110



MOTORREDUCTOR PARA GRADES  
 MOTORREDUCTOR PARA PUERTAS ENROLLABLES  
 MOTO RÉDUCTEUR POUR PORTES ENROULABLES  
 GEAR MOTOR FOR ROLLING SHUTTERS

# ROTOR



CE



UniROTOR 150    UniROTOR 180    BiROTOR 420

Acoplamiento / Boca de eje / Emboîture d'arbre / Shaft sleeve	mm	60	60	76
Diámetro total / Diámetro total / Diamètre total / Total diameter	mm	200-220	200-220	240-260
Tensão / Tensión / Tension / Voltage	V AC	230	230	230
Potência / Potencia / Puissance / Power	W	600	750	1000
Intensidade / Absorción / Intensité / Absorption	A	2.6	3.26	4.36
Torque / Torque / Moment de force / Torque	N.m	150	180	420
Peso máx. / Peso máx. / Poids max. / Max. weight	Kg	160	200	360
Velocidade / Velocidad / Vitesse / Speed	rpm	10	10	10
Tempo de trabalho / Tiempo de trabajo / Temps de travail / Working cycle	min.	4	4	4
Índice de protecção / Índice de protección / Indice de protection / IP Code	(IEC 60529)	IP 30	IP 30	IP 30
Temperatura / Temperatura / Température / Temperature	°C	-20 ~ +70	-20 ~ +70	-20 ~ +70

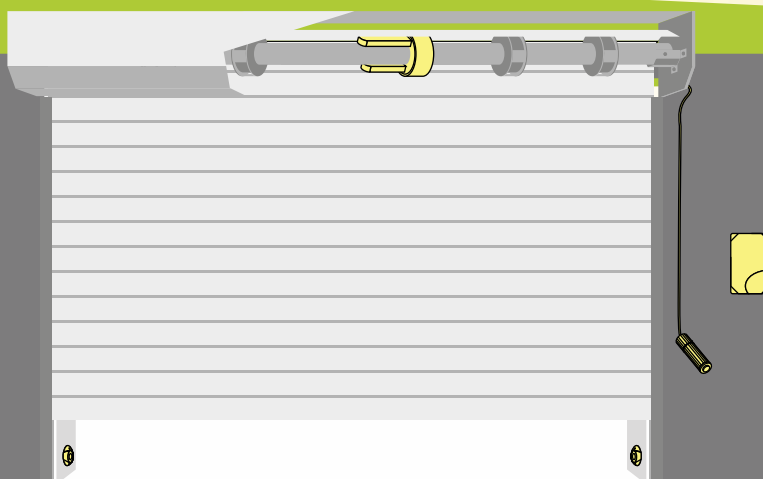

Motorreductor para grades de enrolar com molas de fita  
 / Motorreductor para puertas enrollables con muelles de fleje  
 / Moto réducteur pour portes enroulables avec ressorts  
 / Gear motor for coil spring balanced rolling shutters

Aplicável em grades já montadas, sem necessidade de desmontar o veio  
 / Aplicable en puertas ya montadas, sin necesidad de desmantelar el eje  
 / Applicable dans portes déjà montées, sans besoin de démonter l'arbre  
 / Installation in previously mounted shutters without disassembling the axle



Uso com tambores de molas com diâmetro de 200 a 260mm  
 / Para usar con poleas de muelles de 200 a 260mm en diámetro  
 / Pour utiliser avec boîte à ressort de 200 a 260mm de diamètre  
 / To use with spring barrels of 200 to 260mm in diameter

Fins de curso mecânicos  
 / Finales de carrera mecánicas  
 / Fins de course mécaniques  
 / Mechanical limit switches

Electrofreio de segurança com desbloqueio manual de emergência  
 / Electrofreno de seguridad con desbloqueo manual de emergencia  
 / Électro-frein de sécurité avec déblocage manuel d'urgence  
 / Security electrobrake with emergency manual opening

Motor simples ou duplo  
 / Motor simple o doble  
 / Moteur simple ou double  
 / Single or double motor

Corpo em liga metálica muito resistente  
 / Cuerpo en aleación muy resistente  
 / Corps en alliage très résistant  
 / Body made of high resistance alloy

Kit motor / Kit motor / Kit moteur / Operator's kit



Kit <b>UniROTOR 150</b>	02.536150
Kit <b>UniROTOR 180</b>	02.536180
Kit <b>BIROTOR 420</b>	02.537420

Motor / Motor / Moteur / Operator

Sem electrofreio / Sin electrofreno / Sans électro-frein / Without electric brake

<b>UniROTOR 150</b>	02.536159
<b>UniROTOR 180</b>	02.536189
<b>BIROTOR 420</b>	02.537429

Accessórios / Accesorios  
 / Accessoires / Accessories

Electrofreio para Electrofreno para Électro frein pour Electric brake for <b>Uni/BIROTOR</b>	02.539990
Caixa-cofre de embutir (rosca) Caja fuerte empotrable (roscado) Coffre fort encastrable (tordant) Flush mount safe box (unscrew)	02.320106
Caixa-cofre de embutir (alavanca) Caja fuerte empotrable (palanca) Coffre fort encastrable (levier) Flush mount safe box (lever)	02.539100

Quadros de controlo / Cuadros de maniobras / Cadres de commande / Control boards



<b>CTR30</b>	sem receptor sin receptor sans récepteur without receiver	02.270230
<b>SKTB</b>	com receptor e botões con receptor y botones avec récepteur et boutons with receiver and push buttons	02.400208
<b>CTR18</b>	sem receptor sin receptor sans récepteur without receiver	02.270118



MOTOR TUBULAR PARA GRADES DE ENROLAR INDUSTRIAIS  
 MOTOR TUBULAR PARA PUERTAS ENROLLABLES INDUSTRIALES  
 MOTEUR TUBULAIRE POUR PORTES ENROULABLES INDUSTRIELLES  
 TUBULAR MOTOR FOR INDUSTRIAL ROLLING SHUTTERS

# SMM-100|230



CE



Diâmetro da coroa / Diámetro de la corona / Diamètre de la couronne / Crown diameter	mm	93
Tensão / Voltaje / Tension / Voltage	VAC	230
Potência / Potencia / Puissance / Power	W	680
Intensidade / Absorción / Intensité / Absorption	A	3
Torque / Torque / Moment de force / Torque	N.m	230
Velocidade / Velocidad / Vitesse / Speed	rpm	12
Tempo de trabalho / Tiempo de trabajo / Temps de travail / Working cycle	min.	4
Protecção térmica / Protección térmica / Protection thermique / Thermal protection	°C	130
Índice de protecção / Índice de protección / Indice de protection / IP Code	(IEC 60529)	IP 44



**Motor tubular para grades de enrolar industriais**  
 / Motor tubular para puertas enrollables industriales  
 / Moteur tubulaire pour portes enrollables industrielles  
 / Tubular motor for industrial rolling shutters

**Após instalação, o motor fica praticamente invisível**  
 / Después de la instalación, el motor es prácticamente invisible  
 / Après l'installation, le moteur est pratiquement invisible  
 / After installation, the motor is virtually invisible



**Coroa perfurada em aço**  
 / Corona perforada de acero  
 / Couronne perforée en acier  
 / Perforated steel crown

**Fins de curso mecânicos de muito fácil afinação**  
 / Finales de carrera mecánicas de ajuste muy fácil  
 / Fins de course mécaniques de réglage très facile  
 / Mechanical limit switches, instant tuning

**Abertura manual de emergência pelo interior**  
 / Apertura manual de emergencia por lo interior  
 / Ouverture manuelle d'urgence pour l'intérieur  
 / Emergency manual opening from the interior

**Corpo tubular com acabamento epoxi**  
 / Cuerpo tubular con acabado epoxi  
 / Corps tubulaire avec peinture époxy  
 / Tubular body with epoxy finish

**Lubrificação permanente**  
 / Lubricación permanente  
 / Lubrification permanente  
 / Permanent lubrication

**Kit motor / Kit motor / Kit moteur / Operator's kit**



+ para veio Ø93mm + pour arbre Ø93mm  
 + para eje Ø93mm + for Ø93mm axle

**Kit SMM 100/230 02.452021**

**Motor / Motor / Moteur / Operator**

+ para veio Ø93mm + pour arbre Ø93mm  
 + para eje Ø93mm + for Ø93mm axle

**SMM 100/230 02.452023**

**Outros acessórios**  
 / Otros accesorios  
 / Autres accessoires  
 / Other accessories

<b>Botoneira de parede</b> Mando de pared Bouton mural Push button station	02.320120
<b>Selector de chave</b> Selector de llave Sélecteur à clé Keyswitch	02.600904
<b>Receptor externo 4 canais</b> Receptor externo 4 canales Récepteur externe 4 canaux External receiver 4 channels	02.400013
<b>Emissor 'Black+Inox' 4 canais</b> Mando 'Black+Inox' 4 canales Émetteur 'Black+Inox' 4 canaux Emitter 'Black+Inox' 4 channels	02.400039
<b>Botoneira de parede sem-fios</b> Mando de pared inalámbrico Bouton mural sans fil Wireless push button station	02.400002
<b>Fotocélulas de parede</b> Fotocélulas de pared Photocellules murales Surface mount photocells	02.400023
<b>Kit sistema fotoelétrico</b> Kit goma fotoelétrica Kit système photoélectrique Photoelectric edge kit	02.270301
<b>Pirilampo 230V com antena</b> Lámpara de destellos 230V con antena Feu clignotant 230V avec antenne Flashing light 230V with antenna	02.400010
<b>Travão excêntrico de segurança 1"</b> Freno excéntrico de seguridad 1" Frein excentrique de sécurité 1" Emergency excentric brake 1"	02.400490

**Quadros de controlo / Cuadros de maniobras / Cadres de commande / Control boards**



<b>SKTB</b>	<b>com receptor e botões</b> con receptor y botones avec récepteur et boutons with receiver and push buttons	02.400208
<b>CTR30</b>	<b>sem receptor</b> sin receptor sans récepteur without receiver	02.270230
<b>CTR18</b>	<b>sem receptor</b> sin receptor sans récepteur without receiver	02.270118

MOTORREDUCTOR PARA GRADES INDUSTRIAIS  
 MOTORREDUCTOR PARA PUERTAS ENROLLABLES INDUSTRIALES  
 MOTO RÉDUCTEUR POUR PORTES ENROULABLES INDUSTRIELLES  
 GEAR MOTOR FOR INDUSTRIAL ROLLING SHUTTERS

# QL-600

**230v** **Heavy duty** **Safety BREAK** **600 Kg**

CE

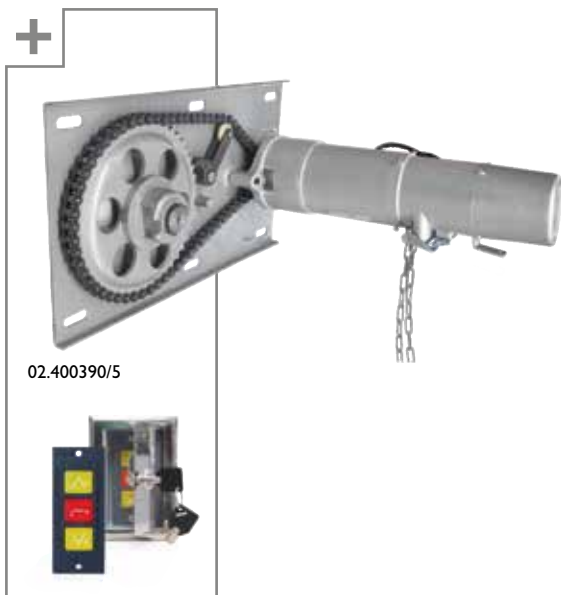

**SKY Master**  
 Professional



Tensão / Voltaje / Tension / Voltage	V AC	230
Potência / Potencia / Puissance / Power	W	370
Intensidade / Absorción / Intensité / Absorption	A	3.9
Torque / Momento flector / Moment de force / Torque	N.m	412
Velocidade / Velocidad / Vitesse / Speed	rpm	5.3
Tempo de trabalho / Tiempo de trabajo / Temps de travail / Working cycle	min.	4
Protecção térmica / Protección térmica / Protection thermique / Thermal protection	°C	110
Peso máx. / Peso máx. / Poids max. / Max. weight	Kg	600
Altura máx. / Altura máx. / Hauteur max. / Max. height	m	6



Motorreductor para grades de enrolar industriais  
 / Motorreductor para puertas enrollables industriales  
 / Moto réducteur pour portes enroulables industrielles  
 / Gear motor for industrial rolling shutters

Base de fixação com cremalheira  
 / Base de fijación con corona  
 / Base de montage avec plateau  
 / Mounting plate with gear wheel

Abertura manual com cadernal integrado  
 / Apertura manual con elevador integrado  
 / Ouverture manuelle avec treuil à chaîne intégrée  
 / Manual opening with integrated hoist



Fins de curso mecânicos em aço temperado e bronze  
 / Finales de carrera mecánicas de acero templado y bronce  
 / Fins de course mécaniques en acier trempé et bronze  
 / Mechanical limit switches of hardened steel and brass

Protecção térmica  
 / Protección térmica  
 / Protection thermique  
 / Thermal protection

Travão por excêntrico para segurança extra  
 / Freno de excéntrico extra para mayor seguridad  
 / Frein excentrique pour plus de sécurité  
 / Eccentric brake for extra security

Corpo com acabamento epoxi  
 / Cuerpo con acabado epoxi  
 / Corps avec peinture époxy  
 / Operator with epoxy finish

Grande desmultiplicação  
 / Gran relación de transmisión  
 / Grand rapport de multiplication  
 / Great gear ratio

Operação automática ou homem-presente  
 / Operación automático o hombre-muerto  
 / Fonctionnement automatique ou homme-mort  
 / Automatic operation or dead-man

Kit motor / Kit motor / Kit moteur / Operator's kit



**Kit QL600** Para veio 1"  
 Para eje Ø1"  
 Pour arbre Ø1"  
 For Ø1" axle 02.400310

**Kit QL600** Para veio Ø70mm  
 Para eje Ø70mm  
 Pour arbre Ø70mm  
 For Ø70mm axle 02.400330

Motor / Motor / Moteur / Operator

**QL600** com cadernal  
 con elevador de cadena  
 avec treuil à chaîne  
 with chain hoist 02.400380

Base de suporte / Base de soporte  
 / Base de montage / Mounting plate

**Base para motor/tubo de 1"** 02.400390  
 Base para motor/eje de 1"  
 Base pour moteur/arbre de 1"  
 Mounting plate for operator/1" axle

**Base para motor/tubo de Ø70mm** 02.400395  
 Base para motor/eje de Ø70mm  
 Base pour moteur/arbre de Ø70mm  
 Mounting plate for operator/Ø70mm axle

Quadros de controlo / Cuadros de maniobras  
 / Cadres de commande / Control boards

**MAXI** com box e botões  
 con receptor y botones  
 avec récepteur et boutons  
 with receptor and push buttons 02.401933

**ZM** módulo de expansão para MAXI 02.401939  
 Módulo de ampliación para MAXI  
 Module d'extension pour MAXI  
 Expansion module for MAXI

**MAXI**



**Outros acessórios**

/ Otros accesorios  
 / Autres accessoires  
 / Other accessories

**Receptor externo 4 canais** 02.400013  
 Receptor externo 4 canales  
 Récepteur externe 4 canaux  
 External receiver 4 channels

**Emissor 'Black+Inox' 4 canais** 02.400039  
 Mando 'Black+Inox' 4 canales  
 Émetteur 'Black+Inox' 4 canaux  
 Emitter 'Black+Inox' 4 channels

**Botoneira de parede sem-fios** 02.400002  
 Mando de pared inalámbrico  
 Bouton mural sans fil  
 Wireless push button station

**Selector digital sem fios** 02.400018  
 Teclado digital inalámbrico  
 Clavier numérique sans fil  
 Wireless digital keypad

**Selector de chave** 02.600904  
 Selector de llave  
 Sélecteur à clé  
 Keyswitch

**Fotocélulas de parede** 02.400023  
 Fococélulas de pared  
 Photocellules murales  
 Surface mount photocells

**Kit sistema fotoelétrico** 02.270301  
 Kit goma fotoelétrica  
 Kit système photoélectrique  
 Photoelectric edges kit

**Pirilampo 230V com antena** 02.400010  
 Lámpara de destellos 230V con antena  
 Feu clignotant 230V avec antenne  
 Flashing light 230V with antenna

**Travão excêntrico de segurança 1"** 02.400490  
 Freno excéntrico de seguridad 1"  
 Frein excentrique de sécurité 1"  
 Emergency excentric brake 1"

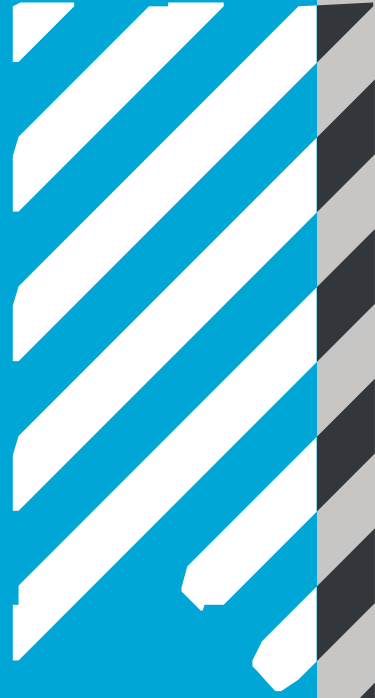

# BK24

# BK6

BARREIRAS AUTOMÁTICAS

BARRERAS AUTOMATICAS

BARRIÈRES AUTOMATIQUES

PARKING BARRIER GATES

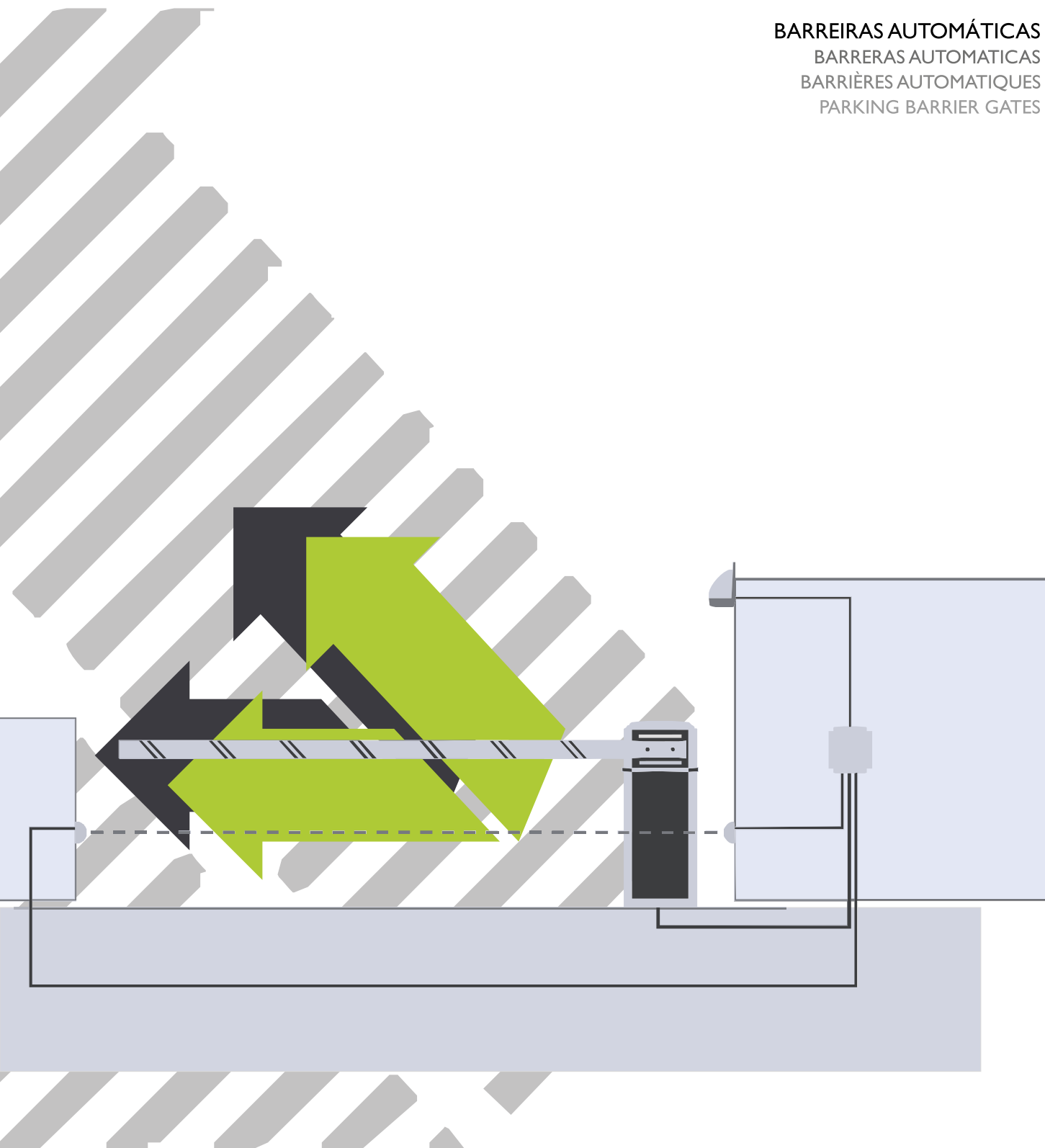

BARREIRA AUTOMÁTICA  
BARRERA AUTOMÁTICA  
BARRIÈRE AUTOMATIQUE  
PARKING BARRIER GATE

# BK24



CE



02.400205



## BK2 - TN

Tensão / Voltaje / Tension / Voltage	V DC	24
Potência / Potencia / Puissance / Power	W	80
Intensidade / Absorción / Intensité / Absorption	A	0.6
Comprimento máx. / Longitud máx. / Longueur max. / Max. length	m	6.0
Abertura total / Apertura total / Ouverture totale / Opening lapse	s	6.0
Fusível / Fusible / Fusible / Fuse	A	10
Frequência / Frecuencia / Fréquence / Frequency	MHz	433 (50m)
Índice de protecção / Índice de protección / Indice de protection / IP Code	(IEC 60529)	IP 55
Temperatura / Temperatura / Température / Temperature	°C	-20 ~ +50
Placa de controlo / Central de mando / Logique de commande / Control card	SkyMaster SKBR-24	

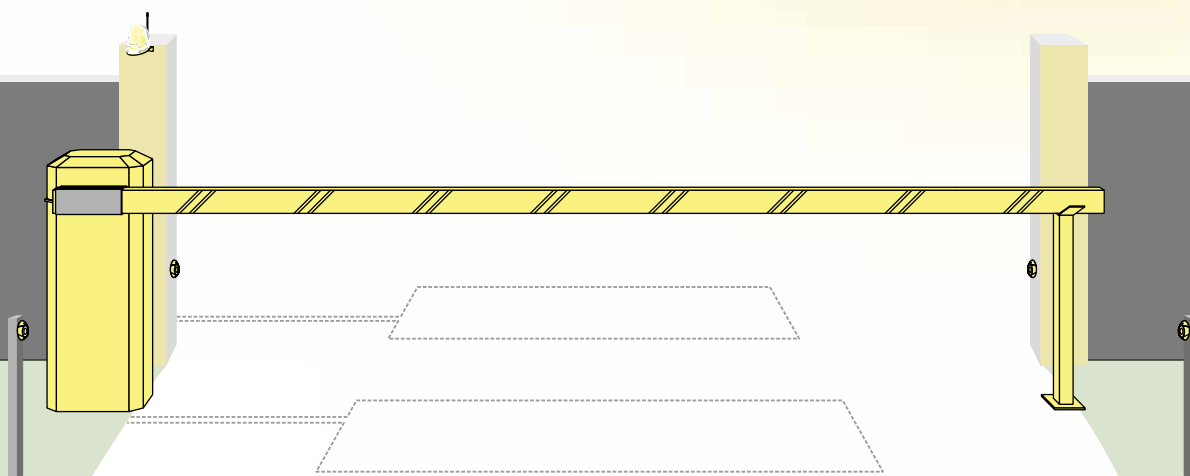

Barreira automática para controlo de acessos, com a flexibilidade dos 24V. A escolha certa para cada situação  
 / Barrera automática para control de acceso, con la flexibilidad de los 24V. La elección correcta para cada situación  
 / Barrière automatique pour contrôle d'accès, avec la flexibilité des 24V. Le choix approprié pour chaque situation  
 / Automatic barrier gate for access control, with the flexibility of the 24V. The right choice for every situation



**BK2 - TN**

Tracção por motoredutor e molas extensoras  
 / Tracción por motorreductor y amortización por muelles  
 / Traction par moto réducteur et ressorts extenseurs  
 / Traction by gear motor and extension springs

Operação muito silenciosa  
 / Funcionamiento muy silencioso  
 / Fonctionnement très silencieux  
 / Very quiet operation

Comprimento da lança até 6m  
 / Longitud de la asta de hasta 6m  
 / Longueur de lisse jusqu'à 6m  
 / Maximum pole length of 6m

Possibilidade de fonte alternativa de energia  
 / Posibilidad de una fuente de alimentación alternativa  
 / Possibilité d'une source d'énergie alternative  
 / Possibility of an alternative power source

Desbloqueio manual de emergência  
 / Desbloqueo manual de emergencia  
 / Débrayage manuel d'urgence  
 / Emergency manual declutch

Codificação Rolling Code anti-cópia  
 / Codificación Rolling Code anticopia  
 / Codage Rolling Code anti-copie  
 / Anti-copy Rolling Code coding

Kit motor / Kit motor / Kit moteur / Operator's kit  
 (comprimento da lança) / (longitud de la asta) / (longueur de la lisse) / (pole length)



Abertura para a direita / Apertura à la derecha / Ouverture à la droite / Right hand opening

**Kit BK2 TN - 4500mm** 02.430090

Abertura para a esquerda / Apertura à la izquierda / Ouverture à la gauche / Left hand opening

**Kit BK2 TN - 4500mm** 02.430190

**Outros acessórios**

/ Otros accesorios  
 / Autres accessoires  
 / Other accessories

**Receptor externo 4 canais** 02.400013  
 Receptor externo 4 canales  
 Récepteur externe 4 canaux  
 External receiver 4 channels

**Emissor 'Black+Inox' 4 canais** 02.400039  
 Mando 'Black+Inox' 4 canales  
 Émetteur 'Black+Inox' 4 canaux  
 Emitter 'Black+Inox' 4 channels

**Botoneira de parede sem-fios** 02.400002  
 Mando de pared inalámbrico  
 Bouton mural sans fil  
 Wireless push button station

**Selector digital sem fios** 02.400018  
 Teclado digital inalámbrico  
 Clavier numérique sans fil  
 Wireless digital keypad

**Selector de chave** 02.600904  
 Selector de llave  
 Sélectionneur à clé  
 Keyswitch

**Fotocélulas de parede** 02.400023  
 Fococélulas de pared  
 Photocellules murales  
 Surface mount photocells

**Kit sistema fotoeléctrico** 02.270300  
 Kit goma fotoeléctrica  
 Kit système photoélectrique  
 Photoelectric edges kit

**Pirilampo 230V com antena** 02.400010  
 Lámpara de destellos 230V con antena  
 Feu clignotant 230V avec antenne  
 Flashing light 230V with antenna

**Espira magnética 2 canais** 02.270201  
 Bucle magnético 2 canales  
 Détecteur à boucle 2 canaux  
 Loop detector 2 channels

Motor / Motor / Moteur / Operator

**BK2** abertura para a direita 02.431090  
 apertura à la derecha  
 ouverture pour la droite  
 right hand opening

**BK2** abertura para a esquerda 02.431190  
 apertura à la izquierda  
 ouverture pour la gauche  
 left hand opening



02.431200

Lança / Asta / Lisse / Pole

**TR** lança com 5000mm 02.431202  
 asta con 5000mm  
 lisse avec 5000mm  
 pole with 5000mm

**TS** lança com 5000mm 02.431203  
 asta con 5000mm  
 lisse avec 5000mm  
 pole with 5000mm

**Soporte ajustável para lança** 02.431200  
 Soporte ajustable para asta  
 Support ajustable pour lisse  
 Adjustable pole support

Quadros de controlo / Cuadros de maniobras  
 / Cadres de commande / Control boards

**SKBR-24** com receptor e botões 02.400205  
 con receptor y botones  
 avec récepteur et boutons  
 with receptor and push buttons

BARREIRA AUTOMÁTICA  
BARRERA AUTOMÁTICA  
BARRIÈRE AUTOMATIQUE  
PARKING BARRIER GATE

# BK6



CE



02.401932



		BK6 - TN	BK6 - TR	BK6 - TS
Tensão / Voltaje / Tension / Voltage	V AC	230	230	230
Potência / Potencia / Puissance / Power	W	90	90	90
Intensidade / Absorción / Intensité / Absorption	A	0.6	0.6	0.6
Comprimento máx. / Longitud máx. / Longueur max. / Max. length	m	6.5	5	5
Abertura total / Apertura total / Ouverture totale / Opening lapse	s	6.0	6.0	6.0
Fusível / Fusible / Fusible / Fuse	A	10	10	10
Frequência / Frecuencia / Fréquence / Frequency	MHz	433 (50m)	433 (50m)	433 (50m)
Índice de protecção / Índice de protección / Indice de protection / IP Code	(IEC 60529)	IP 44	IP 44	IP 44
Temperatura / Temperatura / Température / Temperature	°C	-20 ~ +50	-20 ~ +50	-20 ~ +50
Placa de controlo / Central de mando / Logique de commande / Control card		SkyMaster SKBR-230		

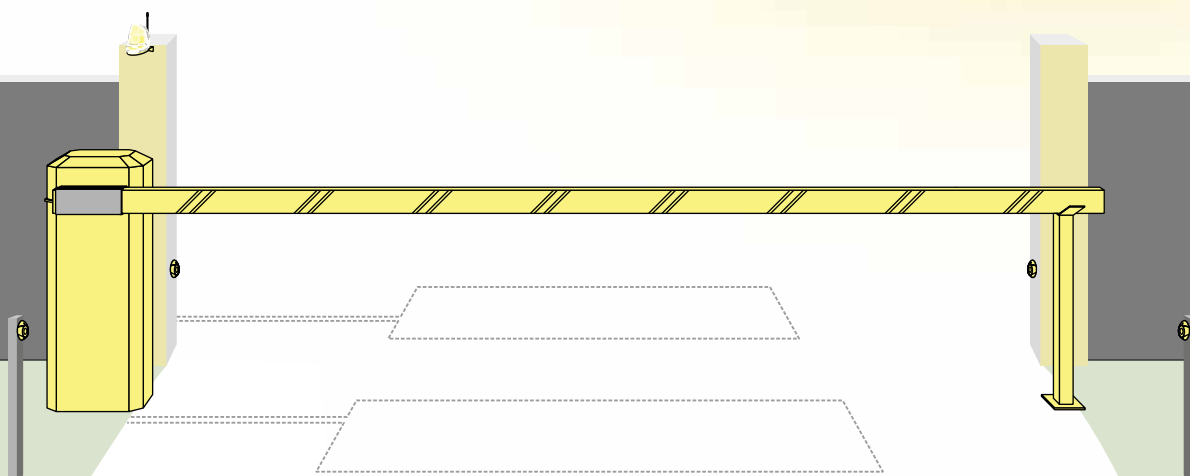

Barreira automática para controlo de acessos, com 3 modelos de lança. A escolha certa para cada situação  
 / Barrera automática para control de acceso, con 3 modelos de asta. La elección correcta para cada situación  
 / Barrière automatique pour contrôle d'accès, avec 3 modèles de lisse. Le choix approprié pour chaque situation  
 / Automatic barrier gate for access control, with 3 pole models. The right choice for every situation

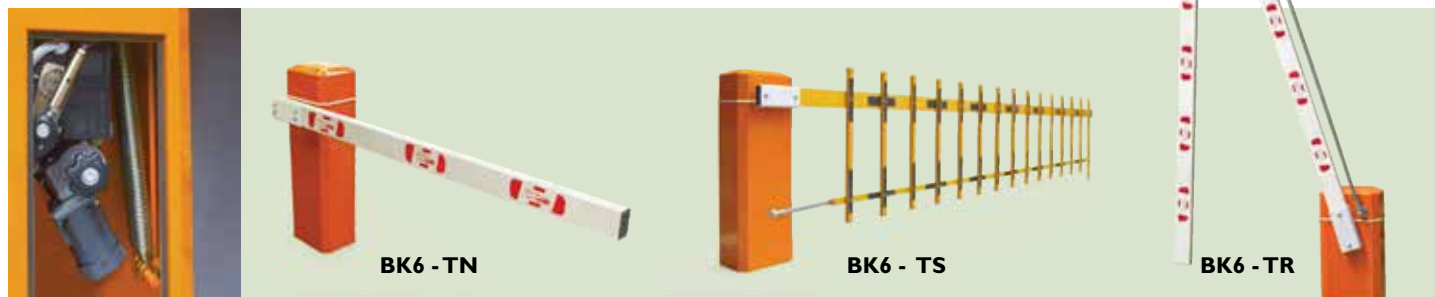

Tracção por motoreductor e molas extensoras

/ Tracción por motorreductor y amortización por muelles  
 / Traction par moto réducteur et ressorts extenseurs  
 / Traction by gear motor and extensor springs

Lança simples, repartida ou com saia

/ Asta simple, plegable o con seto  
 / Lisse simple, pliable ou avec haie  
 / Pole types: regular, folding and skirted

Comprimento da lança até 6,5m

/ Longitud de la asta de hasta 6,5m  
 / Longueur de lisse jusqu'à 6.5m  
 / Maximum pole length of 6.5m

Operação muito silenciosa

/ Funcionamiento muy silencioso  
 / Fonctionnement très silencieux  
 / Very quiet operation

Desbloqueio manual de emergência

/ Desbloqueo manual de emergencia  
 / Débrayage manuel d'urgence  
 / Emergency manual declutch

Codificação Rolling Code anti-cópia

/ Codificación Rolling Code anticopia  
 / Codage Rolling Code anti-copie  
 / Anti-copy Rolling Code coding

Kit motor / Kit motor / Kit moteur / Operator's kit  
 (comprimento da lança) / (longitud de la asta) / (longueur de la lisse) / (pole length)



Abertura para a direita / Apertura à la derecha / Ouverture à la droite / Right hand opening

Kit **BK6 TN - 4500mm** 02.430010

Kit **BK6 TN - 5500mm** 02.430011

Kit **BK6 TN - 6500mm** 02.430012

Kit **BK6 TR - 5000mm** 02.430022

Kit **BK6 TS - 5000mm** 02.430033

Abertura para a esquerda / Apertura à la izquierda / Ouverture à la gauche / Left hand opening

Kit **BK6 TN - 4500mm** 02.430110

Kit **BK6 TN - 5500mm** 02.430111

Kit **BK6 TN - 6500mm** 02.430112

Kit **BK6 TR - 5000mm** 02.430122

Kit **BK6 TS - 5000mm** 02.430133

Motor / Motor / Moteur / Operator

**BK6** abertura para a direita 02.431010  
 apertura à la derecha  
 ouverture pour la droite  
 right hand opening

**BK6** abertura para a esquerda 02.431110  
 apertura à la izquierda  
 ouverture pour la gauche  
 left hand opening



Lança / Asta / Lisse / Pole

**TR** lança com 5000mm 02.431202  
 asta con 5000mm  
 lisse avec 5000mm  
 pole with 5000mm

**TS** lança com 5000mm 02.431203  
 asta con 5000mm  
 lisse avec 5000mm  
 pole with 5000mm

Soporte ajustável para lança 02.431200  
 Soporte ajustable para asta  
 Support ajustable pour lisse  
 Pole ajustable support

Quadros de controlo / Cuadros de maniobras  
 / Cadres de commande / Control boards

**SKBR-230** com receptor e botões 02.400203  
 con receptor y botones  
 avec récepteur et boutons  
 with receptor and push buttons

Outros acessórios

/ Otros accesorios  
 / Autres accessoires  
 / Other accessories

Fotocélulas de parede 02.400023  
 Fotocélulas de pared  
 Photocellules murales  
 Surface mount photocells

Espira magnética 2 canais 02.270201  
 Bucle magnético 2 canales  
 Détecteur à boucle 2 canaux  
 Loop detector 2 channels

Kit sistema fotoeléctrico 02.270300  
 Kit goma fotoeléctrica  
 Kit système photoélectrique  
 Photoelectric edges kit

Selector digital sem fios 02.400018  
 Teclado digital inalámbrico  
 Clavier numérique sans fil  
 Wireless digital keypad

ACESSÓRIOS E QUADROS DE CONTROLO  
ACESSORIOS Y CUADROS DE MANDO  
ACCESSOIRES ET CARTES DE CONTRÔLE  
ACCESSORIES AND CONTROL CARDS

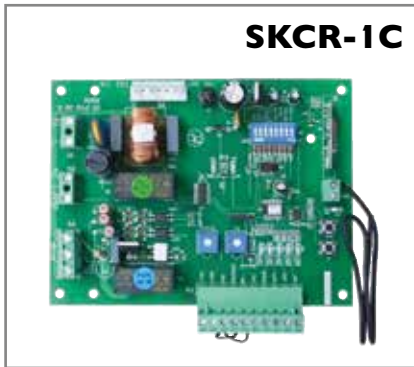

**SKCR-1C**



CE

02.400210

Tensão / Tensión / Tension / Voltage	V AC	230
Alimentação 1 motor / Alimentación 1 motor / Alimentation 1 moteur / 1 Motor supply	V AC - W max	230 - 350
Alimentação luz / Alimentación luz / Alimentation lumière / Light supply	V AC	230
Alimentação dispositivos / Alimentación dispositivos / Alimentation dispositifs / Devices supply	V DC	18
Tempo de trabalho / Tiempo de trabajo / Temps de travail / Working cycle	S	0 ~ 120
Tempo de pausa / Tiempo de pausa / Temps de pause / Pause cycle	S	0 ~ 70
Frequência / Frecuencia / Fréquence / Frequency	MHz	433
Emissores máx. / Emisores máx. / Émetteurs max. / Max. transmitters	X	120
Fusível geral / Fusible general / Fusible principal / Main fuse	A	5
Temperatura / Temperatura / Température / Temperature	°C	-20 ~ +60
Dimensão / Dimensión / Dimension / Dimension	mm	150x112x38

Sem caixa / Sin caja / Sans boîte / Without box

Funções  
/ Funciones  
/ Fonctions  
/ Functions

Passo-a-passo / Paso-a-paso / Pas à pas / Step-by-step
Fecho automático / Auto-cierre / Fermeture automatique / Auto-close
Abertura peatonal / Apertura peatonal / Ouverture piétonnière / Pedestrian opening
Abrandamento/força reguláveis / Desaceleración/ fuerza regulables / Ralentissement/force réglables / Adjustable deceleration/sensitivity
Fotocélulas abertura/fecho / Fotocelulas apertura/cierre / Photocellules ouvrir/fermer / Photocells open/close
Fins-de-curso externos NO-NC / Finales de carrera externos NA-NC / Fins de cours externes NO-NF / NO-NC external limit switches
'Start' externo / Arranque externo / Déclencheur externe / External start command

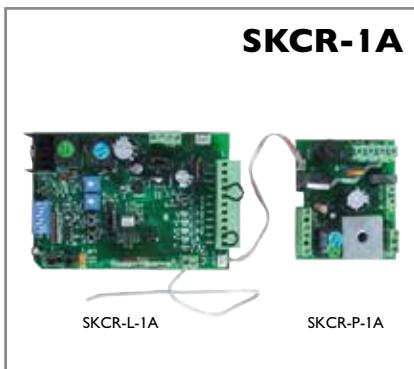

**SKCR-1A**

SKCR-L-1A

SKCR-P-1A

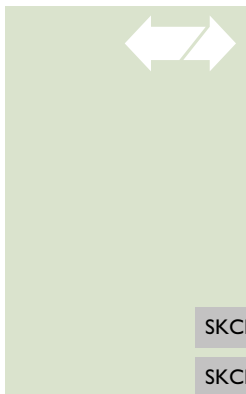

CE

SKCR-L-1A 02.400230

SKCR-P-1A 02.400231

Tensão / Tensión / Tension / Voltage	V AC	230
Alimentação 1 motor / Alimentación 1 motor / Alimentation 1 moteur / 1 Motor supply	V DC - W max	24 - 110
Alimentação pirlampo / Alimentación destellos / Alimentation clignotant / Flashing light supply	V AC / V DC	230 / 24
Alimentação dispositivos / Alimentación dispositivos / Alimentation dispositifs / Devices supply	V DC	24
Tempo de trabalho / Tiempo de trabajo / Temps de travail / Working cycle	S	0 ~ 120
Tempo de pausa / Tiempo de pausa / Temps de pause / Pause cycle	S	0 ~ 70
Frequência / Frecuencia / Fréquence / Frequency	MHz	433
Emissores máx. / Emisores máx. / Émetteurs max. / Max. transmitters	X	120
Fusível geral / Fusible general / Fusible principal / Main fuse	A	5
Temperatura / Temperatura / Température / Temperature	°C	-25 ~ +50
Dimensão / Dimensión / Dimension / Dimension	mm	93x197x38

Sem caixa / Sin caja / Sans boîte / Without box

Funções  
/ Funciones  
/ Fonctions  
/ Functions

Passo-a-passo / Paso-a-paso / Pas à pas / Step-by-step
Fecho automático / Auto-cierre / Fermeture automatique / Auto-close
Abertura peatonal / Apertura peatonal / Ouverture piétonnière / Pedestrian opening
Sincronia 2 folhas / Sincronia 2 hojas / Synchronie 2 vantaux / 2 leaves synchronization
Abrandamento/força reguláveis / Desaceleración/ fuerza regulables / Ralentissement/force réglables / Adjustable deceleration/sensitivity
Fotocélulas abertura/fecho / Fotocelulas apertura/cierre / Photocellules ouvrir/fermer / Photocells open/close
Fins-de-curso externos NO-NC / Finales de carrera externos NA-NC / Fins de cours externes NO-NF / NO-NC external limit switches
Bateria de emergência / Bateria de emergencia / Batterie d'urgence / Emergency battery
'Start' externo / Arranque externo / Déclencheur externe / External start command
'Stop' emergência / Parada de emergencia / Arrêt d'urgence / Emergency stop

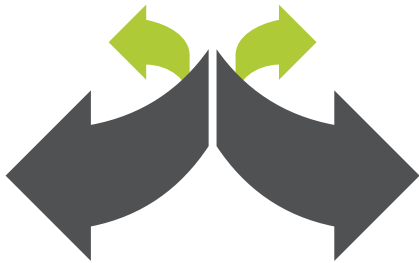

**SKBT-24**

Tensão / Tensión / Tension / Voltage	V AC	230
Alimentação motor / Alimentación motor / Alimentation moteur / Motor supply	V DC - W max	24 - 300
Alimentação luz / Alimentación luz / Alimentation lumière / Light supply	V AC - W max	230 - 60
Alimentação dispositivos / Alimentación dispositivos / Alimentation dispositifs / Devices supply	V DC	12 ~ 15
Tempo de trabalho / Tiempo de trabajo / Temps de travail / Working cycle	S	5 ~ 63
Tempo de pausa / Tiempo de pausa / Temps de pause / Pause cycle	S	0 ~ 210
Frequência / Frecuencia / Fréquence / Frequency	MHz	433
Emissores máx. / Emisores máx. / Émetteurs max. / Max. transmitters	X	25
Fusível geral / Fusible general / Fusible principal / Main fuse	A	2.5
Índice de protecção / Índice de protección / Indice de protection / IP Code	(IEC 60529)	IP 44
Dimensão / Dimensión / Dimension / Dimension	mm	190x250x110



02.400216

Funções / Funciones / Fonctions / Functions	Passo-a-passo / Paso-a-paso / Pas à pas / Step-by-step
	Fecho automático / Auto-cierre / Fermeture automatique / Auto-close
	Modo condomínio / Modalidad condominio / Mode condominium / Condominium mode
	Abertura pedonal / Apertura peatonal / Ouverture piétonnière / Pedestrian opening
	Fechadura eléctrica / Cerradura eléctrica / Serrure électrique / Electric lock
	Sensibilidade/força reguláveis / Sensibilidad/fuerza regulables / Sensibilité/force réglables / Adjustable torque/sensitivity
	2 contactos fotocélulas / 2 contactos fotocelulas / 2 contacts pour photocellules / 2 photocell contacts
	Stand-by / Stand-by / Veille / Stand-by - 4W



**SKBT-230**

Tensão / Tensión / Tension / Voltage	V AC	230
Alimentação motor / Alimentación motor / Alimentation moteur / Motor supply	V AC - W max	230 - 600
Alimentação luz / Alimentación luz / Alimentation lumière / Light supply	V AC - W max	230 - 25
Alimentação dispositivos / Alimentación dispositivos / Alimentation dispositifs / Devices supply	V DC - W max	12 ~ 24 - 50
Tempo de pausa / Tiempo de pausa / Temps de pause / Pause cycle	S	1 ~ 120
Frequência / Frecuencia / Fréquence / Frequency	MHz	433
Emissores máx. / Emisores máx. / Émetteurs max. / Max. transmitters	X	25
Fusível geral / Fusible general / Fusible principal / Main fuse	A	5
Índice de protecção / Índice de protección / Indice de protection / IP Code	(IEC 60529)	IP 44
Dimensão / Dimensión / Dimension / Dimension	mm	230x280x100



02.400220

Funções / Funciones / Fonctions / Functions	Passo-a-passo / Paso-a-paso / Pas à pas / Step-by-step
	Fecho automático / Auto-cierre / Fermeture automatique / Auto-close
	Modo condomínio / Modalidad condominio / Mode condominium / Condominium mode
	Fecho imediato / Cierre inmediato / Fermeture immédiate / Immediate closing
	Modo recontagem / Modalidad recuento / Mode décompté / Restart pause mode
	Abertura pedonal / Apertura peatonal / Ouverture piétonnière / Pedestrian opening
	Fechadura eléctrica / Cerradura eléctrica / Serrure électrique / Electric lock
	Abrandamento/força reguláveis / Desaceleración/fuerza regulables / Ralentissement/force réglables / Adjustable deceleration/sensitivity
	2 contactos fotocélulas / 2 contactos fotocelulas / 2 contacts pour photocellules / 2 photocell contacts
	'Stop' emergência / Parada de emergencia / Arrêt d'urgence / Emergency stop

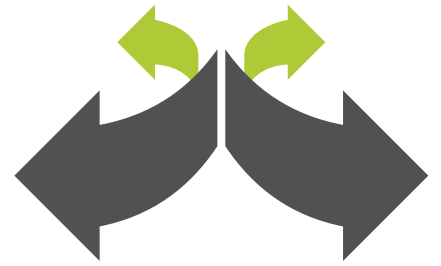

**CTR 33**

CE

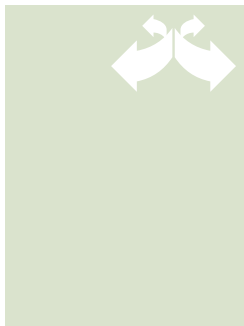

02.270133

Tensão / Tensión / Tension / Voltage	V AC	230
Alimentação 1 motor / Alimentación 1 motor / Alimentation 1 moteur / 1 Motor supply	V DC - W max	15 - 250
Alimentação luz / Alimentación luz / Alimentation lumière / Light supply	V AC - W max	230 - 100
Alimentação pirlampo / Alimentación destellos / Alimentation clignotant / Flashing light supply	V DC - W max	12 - 15
Alimentação dispositivos / Alimentación dispositivos / Alimentation dispositifs / Devices supply	V DC - W max	12 - 3
Carregamento bateria / Alimentación batería / Alimentation batterie / Battery charge	V DC - A	13.5 - 0.5
Tempo de trabalho / Tiempo de trabajo / Temps de travail / Working cycle	S	0 ~ 250
Tempo de pausa / Tiempo de pausa / Temps de pause / Pause cycle	S	0 ~ 250
Fusível geral / Fusible general / Fusible principal / Main fuse	A	10
Temperatura / Temperatura / Température / Temperature	°C	0 ~ +60
Índice de protecção / Índice de protección / Indice de protection / IP Code	(IEC 60529)	IP 44
Dimensão / Dimensión / Dimension / Dimension	mm	180x280x130

Funções  
/ Funciones  
/ Fonctions  
/ Functions

Passo-a-passo / Paso-a-paso / Pas à pas / Step-by-step
Fecho automático / Auto-cierre / Fermeture automatique / Auto-close
Modo condomínio / Modalidad condominio / Mode condominium / Condominium mode
Fotocélulas abertura/fecho / Fotocelulas apertura/cierre / Photocellules ouvrir/fermer / Photocells open/close
Receptor externo extra / Receptor externo extra / Récepteur externe extra / Extra external receiver
Fins-de-curso externos NC / Finales de carrera externos NC / Fins de cours externes NF / NC external limit switches
Bateria de emergência / Bateria de emergencia / Batterie d'urgence / Emergency battery
'Start' externo / Arranque externo / Déclencheur externe / External start command
'Stop' emergência / Parada de emergencia / Arrêt d'urgence / Emergency stop

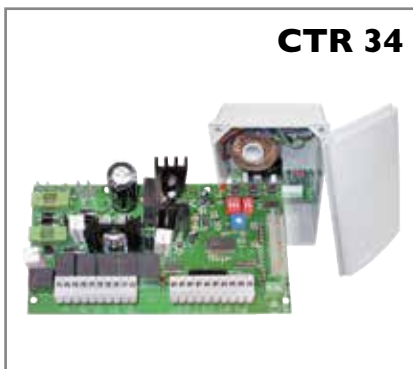

**CTR 34**

CE

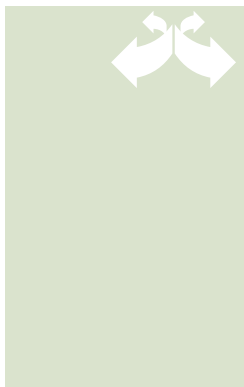

02.270134

Tensão / Tensión / Tension / Voltage	V AC	230
Alimentação 2 motores / Alimentación 2 motores / Alimentation 2 moteurs / 2 Motors supply	V DC - W max	15 - 100
Alimentação luz / Alimentación luz / Alimentation lumière / Light supply	V AC - W max	230 - 100
Alimentação pirlampo / Alimentación destellos / Alimentation clignotant / Flashing light supply	V DC - W max	15/24 - 15
Alimentação fechadura / Alimentación cerradura / Alimentation serrure / Electric lock supply	V DC - W max	15/24 - 15
Alimentação dispositivos / Alimentación dispositivos / Alimentation dispositifs / Devices supply	V DC - W max	13.5/24 - 3
Carregamento bateria / Alimentación batería / Alimentation batterie / Battery charge	V DC - Ah	13.5 - 0.5
Tempo de trabalho / Tiempo de trabajo / Temps de travail / Working cycle	S	0 ~ 120
Tempo de pausa / Tiempo de pausa / Temps de pause / Pause cycle	S	0 ~ 120
Tempo de desfazamento / Retraso de hoja / Délaiage du vantail / Leaf delay	S	0 ~ 25
Fusível geral / Fusible general / Fusible principal / Main fuse	A	10
Temperatura / Temperatura / Température / Temperature	°C	0 ~ +60
Índice de protecção / Índice de protección / Indice de protection / IP Code	(IEC 60529)	IP 44
Dimensão / Dimensión / Dimension / Dimension	mm	186x283x112

Funções  
/ Funciones  
/ Fonctions  
/ Functions

Passo-a-passo / Paso-a-paso / Pas à pas / Step-by-step
Fecho automático / Auto-cierre / Fermeture automatique / Auto-close
Modo condomínio / Modalidad condominio / Mode condominium / Condominium mode
Abertura peatonal / Apertura peatonal / Ouverture piétonnière / Pedestrian opening
Fotocélulas abertura/fecho / Fotocelulas apertura/cierre / Photocellules ouvrir/fermer / Photocells open/close
Receptor externo extra / Receptor externo extra / Récepteur externe extra / Extra external receiver
Bateria de emergência / Bateria de emergencia / Batterie d'urgence / Emergency battery
'Start' externo / Arranque externo / Déclencheur externe / External start command
'Stop' emergência / Parada de emergencia / Arrêt d'urgence / Emergency stop

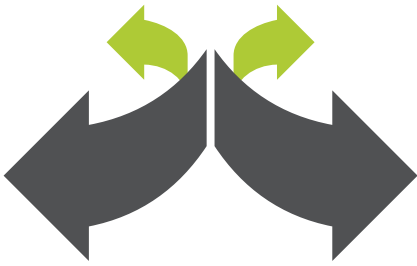

**CTR 18**

Tensão / Tensión / Tension / Voltage	V AC	230
Alimentação 1 motor / Alimentación 1 motor / Alimentation 1 moteur / 1 Motor supply	V AC - W max	230 - 746
Alimentação luz / Alimentación luz / Alimentation lumière / Light supply	V AC - W max	230 - 40
Alimentação fechadura / Alimentación cerradura / Alimentation serrure / Electric lock supply	V DC - W max	12 - 15
Alimentação dispositivos / Alimentación dispositivos / Alimentation dispositifs / Devices supply	V DC - W max	24 - 6
Tempo de trabalho / Tiempo de trabajo / Temps de travail / Working cycle	S	0 ~ 100
Tempo de pausa / Tiempo de pausa / Temps de pause / Pause cycle	S	0 ~ 100
Fusível geral / Fusible general / Fusible principal / Main fuse	A	5
Temperatura / Temperatura / Température / Temperature	°C	0 ~ +60
Índice de protecção / Índice de protección / Indice de protection / IP Code	(IEC 60529)	IP 44
Dimensão / Dimensión / Dimension / Dimension	mm	177x247x92

CE



02.270118

Funções / Funciones / Fonctions / Functions	Passo-a-passo / Paso-a-paso / Pas à pas / Step-by-step
	Fecho automático / Auto-cierre / Fermeture automatique / Auto-close
	Modo condomínio / Modalidad condominio / Mode condominium / Condominium mode
	Fechadura eléctrica / Cerradura eléctrica / Serrure électrique / Electric lock
	Fotocélulas abertura/fecho / Fotocelulas apertura/cierre / Photocellules ouvrir/fermer / Photocells open/close
	Receptor externo extra / Receptor externo extra / Récepteur externe extra / Extra external receiver
	Fins-de-curso externos NC / Finales de carrera externos NC / Fins de cours externes NF / NC external limit switches
	'Start' externo / Arranque externo / Déclencheur externe / External start command
	'Stop' emergência / Parada de emergencia / Arrêt d'urgence / Emergency stop
	Stand-by / Stand-by / Veille / Stand-by - 1W



**CTR 19**

Tensão / Tensión / Tension / Voltage	V AC	230
Alimentação 2 motores / Alimentación 2 motores / Alimentation 2 moteurs / 2 Motors supply	V AC - W max	230 - 746
Alimentação luz / Alimentación luz / Alimentation lumière / Light supply	V AC - W max	230 - 40
Alimentação fechadura / Alimentación cerradura / Alimentation serrure / Electric lock supply	V DC - W max	12 - 15
Alimentação dispositivos / Alimentación dispositivos / Alimentation dispositifs / Devices supply	V DC - W max	24 - 6
Tempo de trabalho / Tiempo de trabajo / Temps de travail / Working cycle	S	0 ~ 100
Tempo de pausa / Tiempo de pausa / Temps de pause / Pause cycle	S	0 ~ 100
Tempo de desfazamento / Retraso de hoja / Délageage du vantail / Leaf delay	S	0 ~ 25
Fusível geral / Fusible general / Fusible principal / Main fuse	A	5
Temperatura / Temperatura / Température / Temperature	°C	0 ~ +60
Índice de protecção / Índice de protección / Indice de protection / IP Code	(IEC 60529)	IP 44
Dimensão / Dimensión / Dimension / Dimension	mm	177x247x92

CE

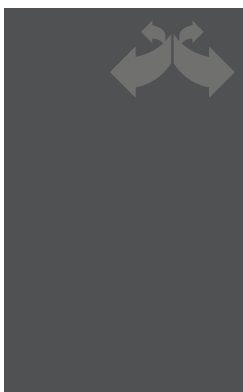

02.270119

Funções / Funciones / Fonctions / Functions	Passo-a-passo / Paso-a-paso / Pas à pas / Step-by-step
	Fecho automático / Auto-cierre / Fermeture automatique / Auto-close
	Modo condomínio / Modalidad condominio / Mode condominium / Condominium mode
	Abertura peatonal / Apertura peatonal / Ouverture piétonnière / Pedestrian opening
	Fechadura eléctrica / Cerradura eléctrica / Serrure électrique / Electric lock
	Fotocélulas abertura/fecho / Fotocelulas apertura/cierre / Photocellules ouvrir/fermer / Photocells open/close
	Receptor externo extra / Receptor externo extra / Récepteur externe extra / Extra external receiver
	Fins-de-curso externos NC / Finales de carrera externos NC / Fins de cours externes NF / NC external limit switches
	'Start' externo / Arranque externo / Déclencheur externe / External start command
	'Stop' emergência / Parada de emergencia / Arrêt d'urgence / Emergency stop
	Stand-by / Stand-by / Veille / Stand-by - 1W



**ECO**



02.401921

CE



**MAXI**



MAXI 02.401933

ZM 02.401939

CE



**ZM**

Tensão / Tensión / Tension / Voltage	V AC 3~ - 1~	400 - 230
Alimentação motor / Alimentación motor / Alimentation moteur / Motor supply	V AC 3~ - 1~	400 - 230
Potência máx. / Potencia máx. / Puissance max. / Max. power	W	1100
Absorção máx. / Absorción máx. / Intensité max. / Max. load	A	4
Tensão de operação / Tensión de operación / Tension de contrôle / Control voltage	V DC	24
Fusível secundário / Fusible secundario / Fusible secondaire / Secondary fuse	mA	250
Temperatura / Temperatura / Température / Temperature	°C	-5 ~ +55
Índice de protecção / Índice de protección / Indice de protection / IP Code	(IEC 60529)	IP 44
Dimensão / Dimensión / Dimension / Dimension	mm	130x190x85

Sem caixa / Sin caja / Sans boîte / Without box

Funções  
/ Funciones  
/ Fonctions  
/ Functions

Homem-presente / Hombre-muerto / Homme mort / Dead man

Abertura por impulso / Apertura de contacto / Ouverture par pulsion / Impulse Open

Tensão / Tensión / Tension / Voltage	V AC 3~ - 1~	400 - 230
Alimentação motor / Alimentación motor / Alimentation moteur / Motor supply	V AC 3~ - 1~	400 - 230
Absorção máx. / Absorción máx. / Intensité max. / Max. load	W - A	2200 - 3.2
Alimentação luz / Alimentación luz / Alimentation lumière / Light supply	V AC	230
Alimentação dispositivos / Alimentación dispositivos / Alimentation dispositifs / Devices supply	V DC - A max	12 ~ 24 - 0.15
Tempo de trabalho / Tiempo de trabajo / Temps de travail / Working cycle	S max	120
Tempo de pausa / Tiempo de pausa / Temps de pause / Pause cycle	S	0 ~ 120
Fusível geral / Fusible general / Fusible principal / Main fuse	A	10
Temperatura / Temperatura / Température / Temperature	°C	-10 ~ +45
Índice de protecção / Índice de protección / Indice de protection / IP Code	(IEC 60529)	IP 44
Dimensão / Dimensión / Dimension / Dimension	mm	167x190x85

Funções extra com módulo ZM / Funciones extra con módulo ZM / Extra fonctions avec module ZM / Extra functions with ZM module

Funções  
/ Funciones  
/ Fonctions  
/ Functions

Homem-presente / Hombre-muerto / Homme mort / Dead man

Abertura por impulso / Apertura de contacto / Ouverture par pulsion / Impulse Open

Fecho automático / Auto-cierre / Fermeture automatique / Auto-close

2 contactos fotocélulas / 2 contactos fotocelulas / 2 contacts pour photocellules / 2 photocell contacts

Barreira pneumática / Barrera de presión de aire / Bord sensible pneumatique / Airwave sensing edge

Luz de cortesia / Luz de presencia / Éclairage de courtoisie / Courtesy light

Semáforo ou pirilampo / Semáforo o lámpara de destellos / Feu de circulation ou feu clignotant / Traffic light or flash light

Receptor externo extra / Receptor externo extra / Récepteur externe extra / Extra external receiver

'Start' externo / Arranque externo / Déclencheur externe / External start command

'Stop' emergência / Parada de emergência / Arrêt d'urgence / Emergency stop



**SKTB-230**

Tensão / Tensión / Tension / Voltage	V AC	230
Alimentação motor / Alimentación motor / Alimentation moteur / Motor supply	V AC - W max	230 - 800
Frequência / Frecuencia / Fréquence / Frequency	MHz	433
Emissores máx. / Emisores máx. / Émetteurs max. / Max. transmitters	X	20
Fusível geral / Fusible general / Fusible principal / Main fuse	A	5
Temperatura / Temperatura / Température / Temperature	°C	-10 ~ +70
Dimensão / Dimensión / Dimension / Dimension	mm	70x120x40

Funções / Funciones / Fonctions / Funcions	<b>Passo-a-passo / Paso-a-paso / Pas à pas / Step-by-step</b>
	<b>3 botões incorporados / 3 pulsadores integrados / 3 bouton intégrés / 3 button station</b>
	<b>Botoneira sem-fios / Mando de pared inalámbrico / Bouton mural sans-fils / Push-button wireless</b>

CE



02.400208



**CTR30**

Tensão / Tensión / Tension / Voltage	V AC	230
Alimentação motor / Alimentación motor / Alimentation moteur / Motor supply	V AC - HP max	230 - 1
Alimentação luz / Alimentación luz / Alimentation lumière / Light supply	V AC - W max	230 - 40
Alimentação dispositivos / Alimentación dispositivos / Alimentation dispositifs / Devices supply	V DC - W max	12 - 1
Tempo de trabalho / Tiempo de trabajo / Temps de travail / Working cycle	S	1 ~ 250
Tempo de pausa / Tiempo de pausa / Temps de pause / Pause cycle	S	1 ~ 250
Fusível geral / Fusible general / Fusible principal / Main fuse	A	5
Temperatura / Temperatura / Température / Temperature	°C	0 ~ +60
Índice de protecção / Índice de protección / Indice de protection / IP Code	(IEC 60529)	IP 56
Dimensão / Dimensión / Dimension / Dimension	mm	88x127x58

Funções / Funciones / Fonctions / Funcions	<b>Passo-a-passo / Paso-a-paso / Pas à pas / Step-by-step</b>
	<b>Fecho automático / Auto-cierre / Fermeture automatique / Auto-close</b>
	<b>Modo cíclico / Modalidad cíclica / Mode cyclique / Cyclic mode</b>
	<b>Fotocélulas só fecho / Focelulas solo cierre / Photocellules seulement fermeture / Photocells just closure</b>
	<b>Receptor externo extra / Receptor externo extra / Récepteur externe extra / Extra external receiver</b>

CE



02.270230



**SKBR-24**

Tensão / Tensión / Tension / Voltage	V AC	230
Alimentação 1 motor / Alimentación 1 motor / Alimentation 1 moteur / 1 Motor supply	V DC - W max	24 - 80
Alimentação luz / Alimentación luz / Alimentation lumière / Light supply	V AC	24
Alimentação dispositivos / Alimentación dispositivos / Alimentation dispositifs / Devices supply	V DC	12
Tempo de trabalho / Tiempo de trabajo / Temps de travail / Working cycle	S	0 ~ 10
Tempo de pausa / Tiempo de pausa / Temps de pause / Pause cycle	S	0 ~ 99
Frequência / Frecuencia / Fréquence / Frequency	MHz	433
Emissores máx. / Emisores máx. / Émetteurs max. / Max. transmitters	X	25
Fusível geral / Fusible general / Fusible principal / Main fuse	A	10
Temperatura / Temperatura / Température / Temperature	°C	-10 ~ +60
Índice de protecção / Índice de protección / Indice de protection / IP Code	(IEC 60529)	IP 22
Dimensão / Dimensión / Dimension / Dimension	mm	167x210x67

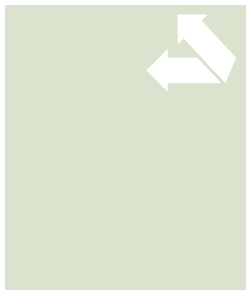

CE

02.400205

Funções  
/ Funciones  
/ Fonctions  
/ Functions

Passo-a-passo / Paso-a-paso / Pas à pas / Step-by-step
Fecho automático / Auto-cierre / Fermeture automatique / Auto-close
Fins-de-curso externos / Finales de carrera externos / Fins de cours externes / External limit switches
Fotocélulas no fecho / Fotocelulas en el cierre / Photocellules dans la fermeture / Photocells on closing
Espira magnética / Detector espira magnética / Détecteur à boucle / Loop detector
Barreira pneumática / Barrera de presión de aire / Bord sensible pneumatique / Airwave sensing edge
Botoneira 3 botões / Mando de pared 3 botones / Sélecteur 3 boutons / Control station 3 buttons
'Start' externo / Arranque externo / Déclencheur externe / External start command



**SKBR-230**

Tensão / Tensión / Tension / Voltage	V AC	230
Alimentação 1 motor / Alimentación 1 motor / Alimentation 1 moteur / 1 Motor supply	V AC - W max	230 - 90
Alimentação luz / Alimentación luz / Alimentation lumière / Light supply	V AC	230
Alimentação dispositivos / Alimentación dispositivos / Alimentation dispositifs / Devices supply	V DC	12
Tempo de trabalho / Tiempo de trabajo / Temps de travail / Working cycle	S	0 ~ 10
Tempo de pausa / Tiempo de pausa / Temps de pause / Pause cycle	S	0 ~ 99
Frequência / Frecuencia / Fréquence / Frequency	MHz	433
Emissores máx. / Emisores máx. / Émetteurs max. / Max. transmitters	X	25
Fusível geral / Fusible general / Fusible principal / Main fuse	A	10
Temperatura / Temperatura / Température / Temperature	°C	-10 ~ +60
Índice de protecção / Índice de protección / Indice de protection / IP Code	(IEC 60529)	IP 22
Dimensão / Dimensión / Dimension / Dimension	mm	167x210x67

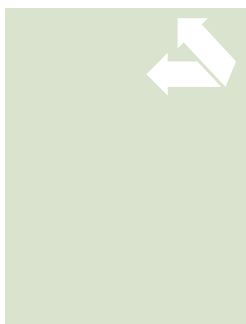

CE

02.400203

Funções  
/ Funciones  
/ Fonctions  
/ Functions

Passo-a-passo / Paso-a-paso / Pas à pas / Step-by-step
Fecho automático / Auto-cierre / Fermeture automatique / Auto-close
Fins-de-curso externos / Finales de carrera externos / Fins de cours externes / External limit switches
Fotocélulas no fecho / Fotocelulas en el cierre / Photocellules dans la fermeture / Photocells on closing
Espira magnética / Detector espira magnética / Détecteur à boucle / Loop detector
Semáforo ou pirilampo / Semáforo o lámpara de destellos / Feu de circulation ou feu clignotant / Traffic light or flash light
Barreira pneumática / Barrera de presión de aire / Bord sensible pneumatique / Airwave sensing edge
Botoneira 3 botões / Mando de pared 3 botones / Sélecteur 3 boutons / Control station 3 buttons
'Start' externo / Arranque externo / Déclencheur externe / External start command



**Emissor 4 canais**  
 / Emisor 4 canales  
 / Émetteur 4 canaux  
 / 4 channels transmitter

**BLACK&INOX** 02.400039



Frequência / Frecuencia / Fréquence / Frequency	433 MHz
Alcance livre / Alcance libre / Portée champ libre / Open range	50 m
Tensão / Tensión / Tension / Voltage	12V DC
Codificação / Codificación / Codage / Coding method	Rolling Code
Tipo de pilha / Tipo de pila / Type de pile / Battery type	27A
Peso / Peso / Poids / Weight	34 g



**Botoneira sem fios**  
 / Mando de pared inalámbrico  
 / Bouton mural sans fil  
 / Wireless push button

02.400002



Frequência / Frecuencia / Fréquence / Frequency	433 MHz
Alcance livre / Alcance libre / Portée champ libre / Open range	50 m
Tensão / Tensión / Tension / Voltage	12V DC
Codificação / Codificación / Codage / Coding method	Rolling Code
Tipo de pilha / Tipo de pila / Type de pile / Battery type	23A
Dimensão / Dimensión / Dimension / Dimension	60x85x22 mm



**Receptor 4 canais**  
 / Receptor 4 canales  
 / Récepteur 4 canaux  
 / 4 channels receiver

02.400013



Tensão / Tensión / Tension / Voltage	24V DC
Frequência / Frecuencia / Fréquence / Frequency	433 MHz
Alcance livre / Alcance libre / Portée champ libre / Open range	50 m
Emissores máx. / Emisores máx. / Émetteurs max. / Max. transmitters	115
Codificação / Codificación / Codage / Coding method	Rolling Code
Dimensão / Dimensión / Dimension / Dimension	55x80x30 mm



**Receptor longo alcance 2 canais**  
 / Receptor largo alcance 2 canales  
 / Récepteur longue portée 2 canaux  
 / Long range 2 channels receiver

02.400021



Tensão / Tensión / Tension / Voltage	12 ~ 24V DC
Frequência / Frecuencia / Fréquence / Frequency	433 MHz
Alcance livre / Alcance libre / Portée champ libre / Open range	100 m
Emissores máx. / Emisores máx. / Émetteurs max. / Max. transmitters	120
Codificação / Codificación / Codage / Coding method	Rolling Code
Dimensão / Dimensión / Dimension / Dimension	58x108x39 mm

**Contacto antena externa / Contacto antena exterior / Contact antenne extérieur / Exterior antenna contact**



**Célula de controlo GSM bi-direcional**  
 / Centro de control GSM bidireccional  
 / Cellule de contrôle GSM bidirectionnelle  
 / 2-way GSM control cell

02.400060



Tensão / Tensión / Tension / Voltage	9-30V AC/DC
Frequência / Frecuencia / Fréquence / Frequency	GSM 900/1800
Registos máx. / Registrados máx. / Enregistrés max. / Max. registered	20
Absorção / Absorción / Intensité / Current load	40-400 mA
Temperatura / Temperatura / Température / Temperature	-20° ~ +70°C
Dimensão / Dimensión / Dimension / Dimension	84x72x32 mm



**Antena externa / Antena exterior / Antenne extérieur / Exterior antenna**

**Relatório por SMS / Notificaciones SMS / Notifications SMS / SMS notifications**



**Botoneira de parede**  
 / Mando de pared  
 / Bouton mural  
 / Push button switch

02.320120



Funções / Funciones / Fonctions / Functions	2
Tensão / Tensión / Tension / Voltage	24 ~ 230V
Dimensão / Dimensión / Dimension / Dimension	56x64x30 mm

**Sobrepor / Superponer / Superposer / Surface mount**



**Selector de chave**  
/ Selector de llave  
/ Sélecteur à clé  
/ Keyswitch

02.270213

CE

Funções / Funciones / Fonctions / Functions	2
Nº de chaves / Nº de llaves / Nº de clés / No. of keys	2
Dimensão / Dimensión / Dimension / Dimension	65x81x34 mm

Sobrepor / Superponer / Superposer / Surface mount



**Selector digital sem fios**  
/ Teclado digital inalámbrico  
/ Clavier numérique sans fil  
/ Wireless digital keypad

02.400018

CE

Frequência / Frecuencia / Fréquence / Frequency	433 MHz
Alcance livre / Alcance libre / Portée champ libre / Open range	50 m
Tensão / Tensión / Tension / Voltage	12V DC
Codificação / Codificación / Codage / Coding method	Rolling Code
Tipo de pilha / Tipo de pila / Type de pile / Battery type	CR2032
Dimensão / Dimensión / Dimension / Dimension	73x85x30 mm

Retro-iluminado / Retroiluminado / Rétro-éclairé / Backlight

Sobrepor / Superponer / Superposer / Surface mount



**Caixa-cofre - alavanca**  
/ Caja fuerte - palanca  
/ Coffre fort - levier  
/ Safe box - lever type

02.539100

ROTOR

CE

Tensão / Tensión / Tension / Voltage - AC/DC	12 ~ 230V
Funções / Funciones / Fonctions / Functions	2
Nº de chaves / Nº de llaves / Nº de clés / No. of keys	2
Dimensão / Dimensión / Dimension / Dimension	121x77x56(32) mm
Método / Método / Méthode / Method	Alavanca / Palanca / Levier / Lever type

Sobrepor / Superponer / Superposer / Surface mount



**Caixa-cofre - rosca**  
/ Caja fuerte - roscado  
/ Coffre fort - tordant  
/ Safe box - screw type

02.320106

ROTOR

CE

Tensão / Tensión / Tension / Voltage - AC/DC	12 ~ 230V
Funções / Funciones / Fonctions / Functions	2
Nº de chaves / Nº de llaves / Nº de clés / No. of keys	2
Dimensão / Dimensión / Dimension / Dimension	160x125x5(95) mm
Método / Método / Méthode / Method	Rosca / Roscado / Tordant / Screw type

Encastrar / Empotrable / Encastrable / Flush mount



**Pirilampo com antena**  
/ Lámpara de destellos con antena  
/ Feu clignotant avec antenne  
/ Flashing light with antenna

02.400010

CE

Tensão / Tensión / Tension / Voltage	230V AC
Lâmpada / Lámpara / Lampe / Light bulb	25W - E14
Absorção / Absorción / Intensité / Current load	90 mA
Intermitência / Destello / Intermittence / Flashing	1 s
Temperatura / Temperatura / Température / Temperature	-35° ~ +90°C
Dimensão / Dimensión / Dimension / Dimension	100x222x125 mm



**Fotocélulas de parede**  
/ Fococélulas de pared  
/ Photocellules murales  
/ Wall mount photocells

02.400023

CE

Tensão / Tensión / Tension / Voltage	12 ~ 24V DC
Alcance livre / Alcance libre / Portée champ libre / Open range	2 ~ 12 m
Tolerância / Tolerancia / Tolérance / Tolerance	<+/-5°
Infra-vermelho / Infra-rojo / Infra-rouge / Infrared	940 nm
Método / Método / Méthode / Method	NO / NC
Temperatura / Temperatura / Température / Temperature	-20° ~ +70°C
Dimensão / Dimensión / Dimension / Dimension	50x76x29 mm



**Interruptor magnético de segurança**  
/ Interruptor magnético de seguridad  
/ Interrupteur magnétique de sécurité  
/ Safety magnetic switch

02.400511

CE

Tensão / Tensión / Tension / Voltage	3V DC
Frequência / Frecuencia / Fréquence / Frequency	868.9 MHz
Alcance livre / Alcance libre / Portée champ libre / Open range	50 m
Tipo de pilha / Tipo de pila / Type de pile / Battery type	LR6 AA
Índice de protecção / Índice de protección / Indice de protection / IP Code	IP 22
Temperatura / Temperatura / Température / Temperature	-20° ~ +85°C
Dimensão / Dimensión / Dimension / Dimension	40x194.5x20 mm / 85x53x36 mm





**Kit sistema fotoelétrico para vedante**  
 / Kit sistema fotoelétrico para goma  
 / Kit système photoélectrique pour joint  
 / Photoeyed edge system kit

## CTR30

02.270301

CE

Tensão / Tensión / Tension / Voltage - AC / DC	12 ~ 24 V
Absorção máx. / Absorción máx. / Intensité max. / Max. load	50 mA
Alcance / Alcance / Portée / Range	1 ~ 10 m
Retardamento / Retraso / Retardement / Delay	40 ms
Infra-vermelho / Infra-rojo / Infra-rouge / Infrared	950 nm
Método / Método / Méthode / Method	NO / NC
Cabo espiral / Cable en espiral / Câble spiralé / Spiral cable	3 - 4.5 - 6 m
Temperatura / Temperatura / Température / Temperature	-20° ~ +55°C
Dimensão / Dimensión / Dimension / Dimension	135x75x65 mm

Sensibilidade regulável / Sensibilidad ajustable / Sensibilité ajustable / Adjustable sensitivity

2 contactos fotocélulas / 2 contactos fotocelulas / 2 contacts pour photocellules / 2 photocell contacts



**Kit sistema fotoelétrico para vedante**  
 / Kit sistema fotoelétrico para goma  
 / Kit système photoélectrique pour joint  
 / Photoeyed edge system kit

## MAXI

02.401959

CE

Tensão / Tensión / Tension / Voltage	24 V DC
Absorção máx. / Absorción máx. / Intensité max. / Max. load	30 mA
Alcance / Alcance / Portée / Range	1 ~ 10 m
Infra-vermelho / Infra-rojo / Infra-rouge / Infrared	950 nm
Retardamento / Retraso / Retardement / Delay	40 ms
Método / Método / Méthode / Method	NO / NC
Cabo espiral / Cable en espiral / Câble spiralé / Spiral cable	5 m
Temperatura / Temperatura / Température / Temperature	-10° ~ +55°C
Dimensão / Dimensión / Dimension / Dimension	155x55x40 mm



**Kit sistema fotoelétrico para vedante**  
 / Kit sistema fotoelétrico para goma  
 / Kit système photoélectrique pour joint  
 / Photoeyed edge system kit

## F-330 F-350 F-390

02.270300

CE

Tensão / Tensión / Tension / Voltage - AC / DC	12 ~ 24 V
Absorção máx. / Absorción máx. / Intensité max. / Max. load	30 mA
Alcance / Alcance / Portée / Range	2 ~ 20 m
Infra-vermelho / Infra-rojo / Infra-rouge / Infrared	950 nm
Retardamento / Retraso / Retardement / Delay	40 ms
Método / Método / Méthode / Method	NO / NC
Cabo espiral / Cable en espiral / Câble spiralé / Spiral cable	3 - 4.5 - 6 m
Temperatura / Temperatura / Température / Temperature	-20° ~ +55°C
Dimensão / Dimensión / Dimension / Dimension	135x75x65 mm

Sensibilidade regulável / Sensibilidad ajustable / Sensibilité ajustable / Adjustable sensitivity

2 contactos fotocélulas / 2 contactos fotocelulas / 2 contacts pour photocellules / 2 photocell contacts



**Travão excêntrico industrial**  
 / Freno excéntrico industrial  
 / Frein excentrique industriel  
 / Industrial excentric brake

FG 40-30

02.400490

CE

Torque máx. / Torque máx. / Moment de force max. / Max. torque	400 N.m
Torque freio / Torque freno / Moment de frein / Lock torque	1150 N.m
Rotação / Rotación / Tours / Rotation	-1 ~ +24 RPM
Contacto / Contacto / Contact / Impulse	12V - STOP
Temperatura / Temperatura / Température / Temperature	-5° ~ +40°C
Índice de protecção / Índice de protección / Indice de protection / IP Code	IP 65
Dimensão / Dimensión / Dimension / Dimension	60x270x180 mm

Aplicação em veios de 1" com escatel / Aplicable en ejes de 1" con chavetero  
 / Applicable dans les arbres de 1" avec rainure de clavette / Applicable to 1" shaft with keyway



**Bateria de emergência**  
 / Batería de emergencia  
 / Batterie de secours  
 / Emergency battery

02.400012

CE

Tensão / Tensión / Tension / Voltage	12 V DC
Capacidade / Capacidad / Capacité / Capacity	7 A
Dimensão / Dimensión / Dimension / Dimension	94x150x65 mm



**Fechadura eléctrica com canhão**  
 / Cerradura eléctrica con bombillo  
 / Serrure électrique avec cylindre  
 / Electric lock with cylinder

40mm (30/10)	02.276021
60mm (30/30)	02.276011

CE

Tensão / Tensión / Tension / Voltage	12V DC
Trinco / Pestillo / Gâche / Latch	Rotativo / Pivotar / Pivoté / Pivoted
Canhão / Bombillo / Cylindre / Cylinder	30/10 - 30/30
Nº de chaves / Nº de llaves / Nº de clés / No. of keys	3
Dimensão / Dimensión / Dimension / Dimension	67x124x36 mm

Sobrepor / Superponer / Superposer / Surface mount



**Desembraiador externo - seccionados**  
 / Desbloqueo exterior - seccionales  
 / Débrayage externe - sectionnel  
 / Declutching key - sectionals

02.400015

CE

Nº de chaves / Nº de llaves / Nº de clés / No. of keys	2
Cabo de aço / Cable de acero / Câble d'acier / Steel cable	2.3 m
Dimensão / Dimensión / Dimension / Dimension	29x29x65 mm



**Adaptador recto para manivela**  
 / Adaptador recto para manubrio  
 / Adaptateur droit pour manche  
 / Straight crank adapter

Kit p/ for SMM 50/50	02.452402
Kit p/ for SMM 60/80-60/100	02.452406

CE

Comprimento / Longitud / Longueur / Length	400 mm
--	--------

Aço galvanizado / Acero galvanizado / Acier galvanisé / Galvanized steel

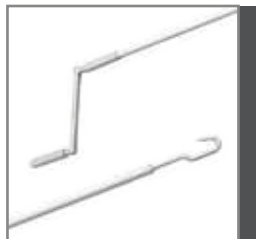

**Manivela articulada**  
 / Manubrio articulado  
 / Manche articulé  
 / Hinged crank

02.452400

CE

Comprimento / Longitud / Longueur / Length	1.8 m
--	-------

Branco lacado / Blanco lacado / Blanc lacqué / White coated  
 Aço e PVC / Acero y PVC / Acier et PVC / Steel and PVC

**Kit desbloqueio exterior**  
 / Kit desbloqueo exterior  
 / Kit débrayage extérieur  
 / Exterior declutch kit

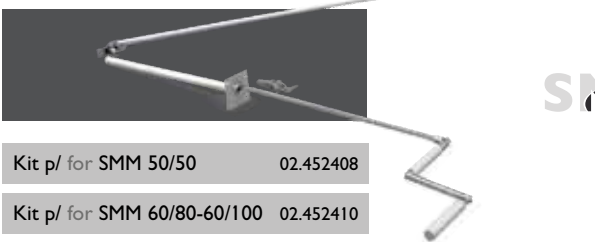

Kit p/ for SMM 50/50	02.452408
Kit p/ for SMM 60/80-60/100	02.452410

CE

Altura / Altura / Hauteur / Height	1.5 m
Espessura parede / Espesor pared / Épaisseur mur / Wall thickness	490 mm (max)
Nº de chaves / Nº de llaves / Nº de clés / No. of keys	2

Branco lacado / Blanco lacado / Blanc lacqué / White coated  
 Aço e PVC / Acero y PVC / Acier et PVC / Steel and PVC



**Fotocélulas com raios infravermelhos**  
 / Fococélula infrarrojo  
 / Photocellule à infra-rouge  
 / Infrared photocell

02.400034

CE

Tensão / Tensión / Tension / Voltage	12 ~ 24V DC
Alcance livre / Alcance libre / Portée champ libre / Open range	40 m
Dimensão / Dimensión / Dimension / Dimension	48x65x29 mm

Possibilidade de fixação até 30 mm de profundidade dentro das paredes  
 Posibilidad de fijación hasta 30 mm dentro de las paredes  
 Possibilité de fixation dans le mur jusqu'à 30mm  
 Possibility of fixing up to 30mm deep inside walls



**Fotocélulas com raios infravermelhos**  
 / Fococélula infrarrojo  
 / Photocellule à infra-rouge  
 / Infrared photocell

02.400033

CE

Tensão / Tensión / Tension / Voltage	12 ~ 24V DC
Alcance livre / Alcance libre / Portée champ libre / Open range	40 m
Dimensão / Dimensión / Dimension / Dimension	41x40x110 mm

## Garantia e Conformidade

Garantía y Conformidad

Garantie et Conformité

Warranty and Accordance

Os equipamentos **SkyMaster**® cumprem com as normas harmonizadas:

**2006/42/CE** - Directiva Máquinas;  
**89/106/CEE** - Directiva Produtos de Construção;  
**2004/108/CE** - Directiva Compatibilidade Electromagnética;  
**2006/95/CE** - Directiva Baixa Tensão;  
**1999/5/CE** - Directiva Equipamentos Rádio e Equipamentos Terminais de Telecomunicações,;

consoante a sua tipologia e composição.

A garantia destes equipamentos é de 2 (dois) anos, estando excluídos o uso indevido do aparelho e o não cumprimento das instruções de aplicação, uso e manutenção.

Qualquer reparação deve ser efectuada exclusivamente por técnicos autorizados **SkyMaster**®.

Los productos **SkyMaster**® cumplen con las normas armonizadas:

**2006/42/CE** - Directiva Máquinas;  
**89/106/CEE** - Directiva Productos de Construcción;  
**2004/108/CE** - Directiva Compatibilidad Electromagnética;  
**2006/95/CE** - Directiva Baja Tensión;  
**1999/5/CE** - Directiva Equipos Radioeléctricos y Equipos Terminales de Telecomunicación,;

de acuerdo con su tipo y composición.

La garantía de estos productos es de 2 (dos) años, estando excluidos el uso indebido del equipo y el incumplimiento de las instrucciones de aplicación, uso y mantenimiento.

Las reparaciones deben ser realizadas únicamente por técnicos autorizados **SkyMaster**®.

Les produits **SkyMaster**® sont conformes aux normes harmonisées:

**2006/42/CE** - Directive Machines;  
**89/106/CEE** - Directive Produits de Construction;  
**2004/108/CE** - Directive Compatibilité Électromagnétique;  
**2006/95/CE** - Directive Basse Tension;  
**1999/5/CE** - Directive Équipements Hertzien et les Équipements Terminaux de Télécommunications,;

en fonction de leur type et composition.

La garantie des produits est de 2 (deux) ans, ont été exclus la mauvaise utilisation de l'équipement et la faille à suivre les instructions d'application, l'utilisation et l'entretien.

Les réparations doivent être effectuées que par un technicien autorisé **SkyMaster**®.

All **SkyMaster**® equipment complies with harmonized standards:

**2006/42/EC** - Machinery Directive;  
**89/106/EC** - Construction Products Directive;  
**2004/108/EEC** - Electromagnetic Compatibility Directive;  
**2006/95/EEC** - Low Voltage Directive;  
**1999/5/EC** - R&TTE Directive,;

according to type and composition.

All equipments have a 2 years warranty period, excluding the misuse of the equipment and failure to follow the instructions for application, use and maintenance.

Any repairs must be performed only by **SkyMaster**® authorized technicians.

# Easy on your life





Distribuidor oficial de automatismos SkyMaster  
Distribuidor oficial de automatismos SkyMaster  
Distribuidor oficial d'automatismes SkyMaster  
Distributeur officiel d'automatismes SkyMaster  
Offizieller Vertriebspartner für SkyMaster-Automatisierungen  
Official distributor of SkyMaster automation systems  
Officiële distributeur van SkyMaster automatiseringssystemen  
Distributore ufficiale di automazioni SkyMaster

[store@daportas.pt](mailto:store@daportas.pt) | [info@daportas.es](mailto:info@daportas.es) | [info@daportas.fr](mailto:info@daportas.fr) | [info@daportas.de](mailto:info@daportas.de)



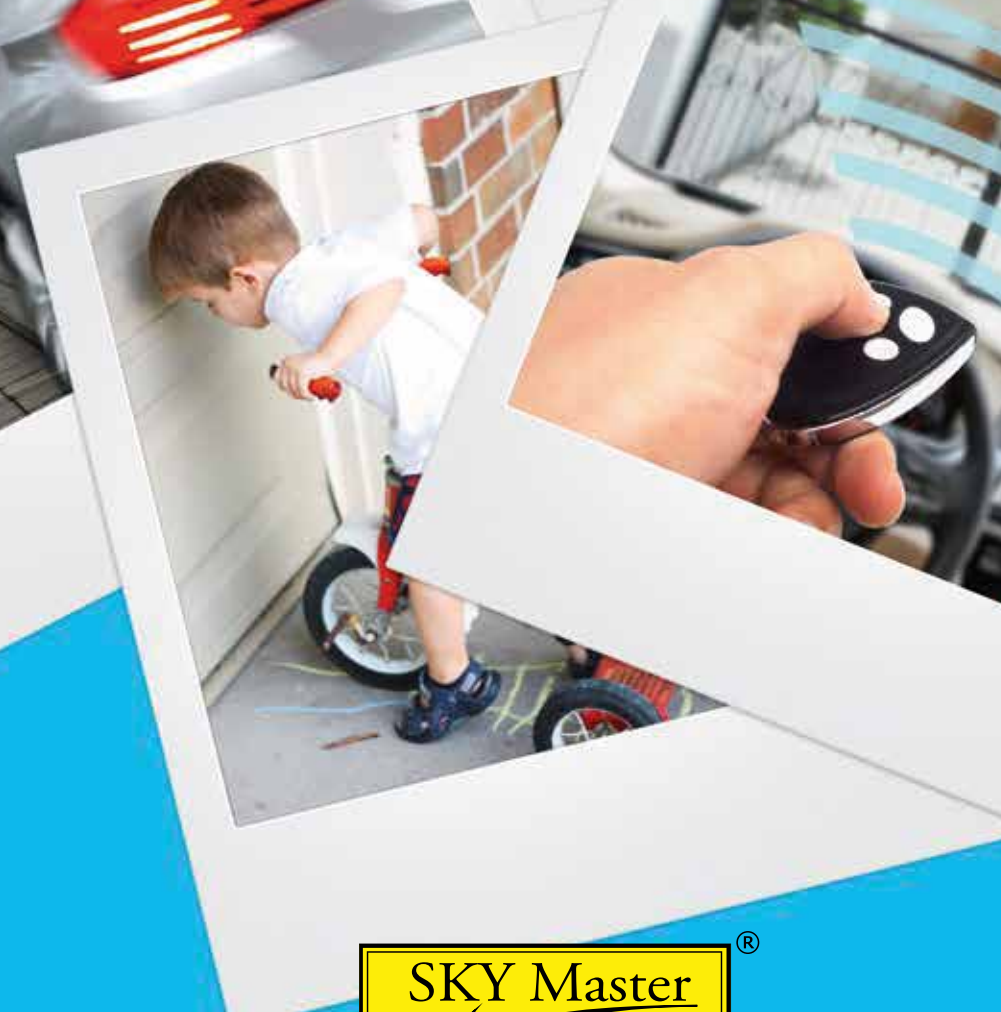

**SKY Master**<sup>®</sup>  
Professional

Easy on your life